

CADprofi Electrical:
Creating and editing
Electrical schemes



Information

We make effort to ensure that information contained in this tutorial is accurate and current. However, if you see any mistakes – please let us know, we appreciate any suggestions. The content of this tutorial may change without any prior notice.

Trademarks

Products listed in this tutorial, in most cases are registered trademarks and are protected by law.

Copyright

This tutorial may be freely redistributed without any need to inform CADprofi company but no changes may be made in the document.

Publication

Created by CADprofi – March 2021

Information about CADprofi

CADprofi is an international company engaged in the development of CAD applications working in the AutoCAD environment (and other Autodesk products), Bricscad GstarCAD, progeCAD, ZWCAD, IntelliCAD and others. CADprofi was founded in Poland in 1996. Now we have two offices in Poland and Germany. Our applications are available in 24 languages and are sold through well-developed network of distributors throughout the world. CADprofi company provides technical support (hotline) and also conducts training in the use of the offered programs. We develop our products only with the most modern programming environment: MFC, C++, ARX. In addition our programs use technology of parametric objects which gives unlimited possibilities to define custom elements (your own objects)

We are the manufacturer of the following products:

- CADprofi HVAC & Piping
- CADprofi Electrical
- CADprofi Mechanical
- CADprofi Architectural
- CP-Symbols
- CP-Manufacturers/CADprofi OEM (many brands made for our industrial partners)

You can find more information about our products on: www.cadprofi.com.

Table of contents

Introduction.....	7
Requirements	8
Settings.....	8
Selecting the language version.....	8
Options in base CAD program	9
Options in CADprofi.....	9
Drawing housing distribution board project.....	10
Adding front page.....	10
User symbols	10
Power distribution schemes creator – inserting symbols	12
Power distribution schemes creator – copying symbols.....	15
Power distribution schemes creator – inserting new columns.....	17
Power distribution schemes creator – describing circuit tables	20
Power distribution schemes creator – saving scheme.....	23
Editing scheme – editing symbols	24
Designing an external circuit control scheme - frames and tables	25
Designing an external circuit control scheme – lines templates.....	27
Designing an external circuit control scheme – circuit lines	28
Describing and editing the scheme -	31
Designing an external circuit control scheme – inserting symbols	34
Generating legend	41
Generating apparatus views.....	45
Selection electrical switchgear	46
Printing the project	48
Creating and printing BOM (bill of materials)	48
Printing the project	50

Introduction

The aim of this tutorial is to acquire practical skills of using CADprofi Electrical when creating electrical schemes. We will learn the functionality of the program when drawing the following housing distribution board:

CADprofi
ul. Struga 26/28
26-600 Radom

ELECTRICAL DOCUMENTATION

Subject: ---

Investor: ---

Designed by: John Kowalski

Comments:

Date: 27.04.2021 Number of sheets: 4

Symbol	1	2	3	4	5	6	7	8
Symbol	1	2	3	4	5	6	7	8
Symbol	1	2	3	4	5	6	7	8
Symbol	1	2	3	4	5	6	7	8
Symbol	1	2	3	4	5	6	7	8

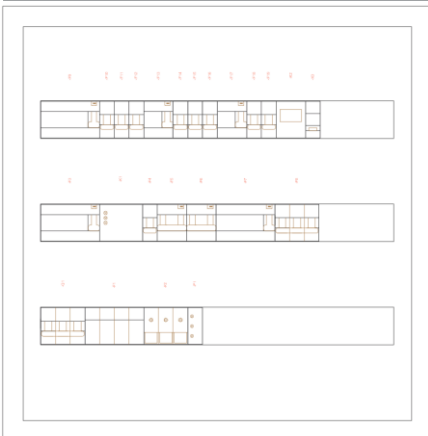
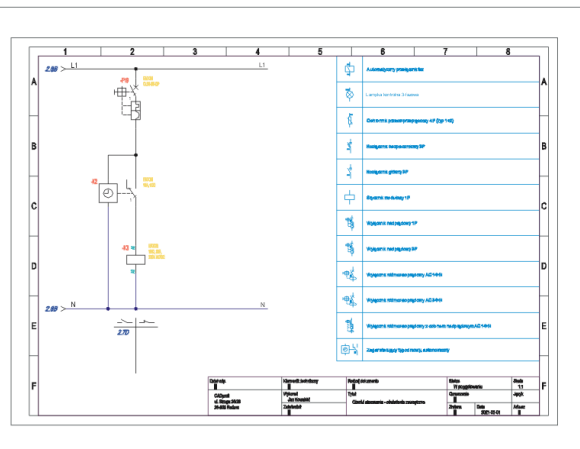
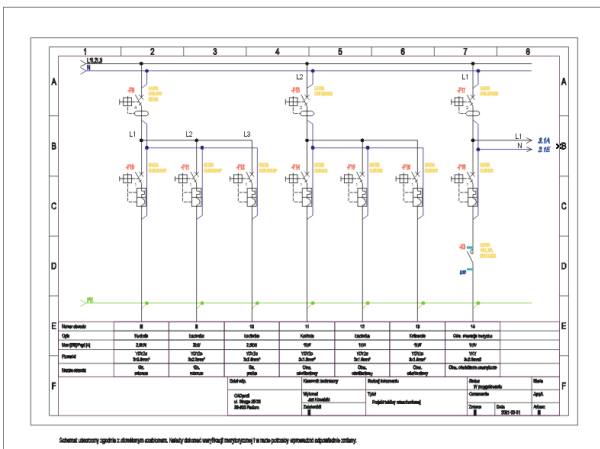

Requirements

In order to perform all exercises from this tutorial you need to install:

- **CADprofi Electrical** or **CADprofi Suite** (commercial, education or [demo version](#)).
- Base CAD program, e.g.: AutoCAD, ARES Commander, BricsCAD, GstarCAD, IntelliCAD, progeCAD, ZWCAD etc.

Settings

Selecting the language version

The Unicode-based user interface is available in 24 languages, including: Polish, English, Bulgarian, Chinese (simplified), Croatian, Czech, Danish, Finnish, French, Greek, Spanish, Dutch, Japanese, Korean, German, Portuguese, Russian, Romanian, Serbian, Slovenian, Swedish, Turkish, Hungarian and Italian.

Language can be easily changed in the configuration program:

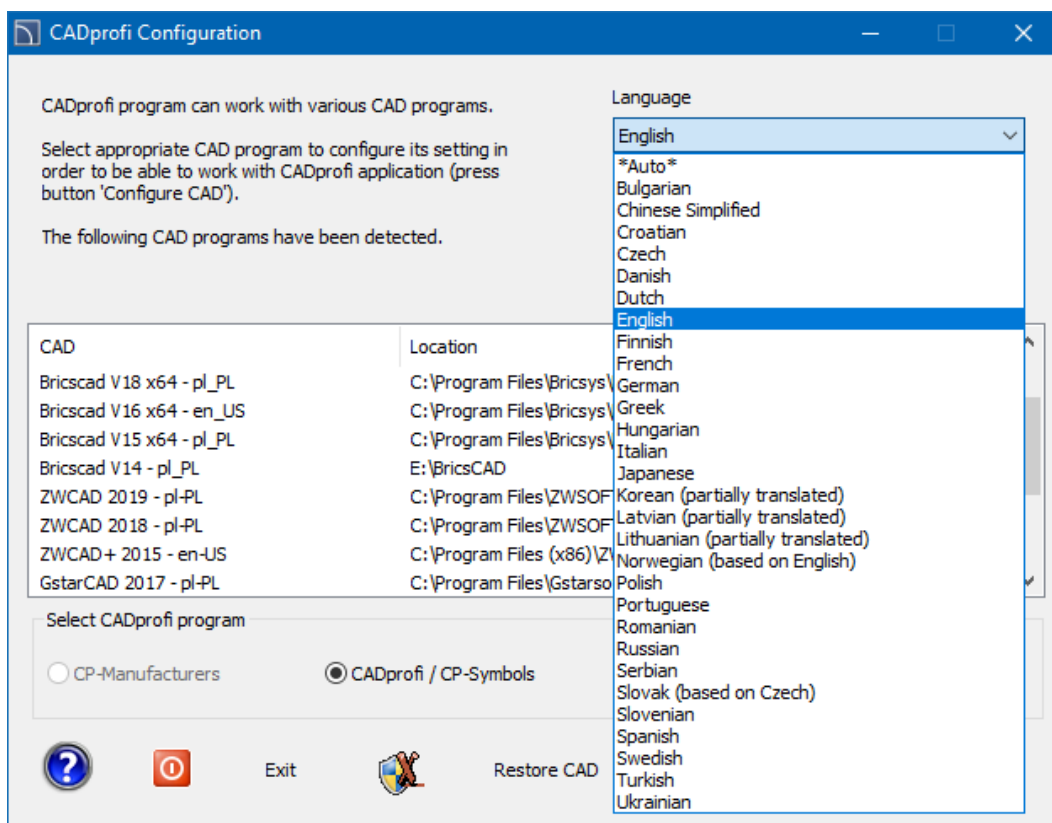

Options in base CAD program

Before we start drawing our scheme let us first set up the settings of both base CAD program and CADprofi.

In the base CAD program let us check the following settings:

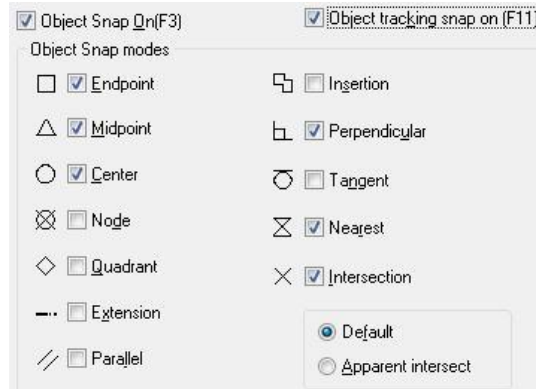

Options in CADprofi

Lets click the *CADprofi - Options* button that is located on the *CADprofi* toolbar.



In the dialog window lets choose the unit of drawing – *millimetres* and lets set the global linetype scale factor for unit: Variable '*Itscale*' – 100.

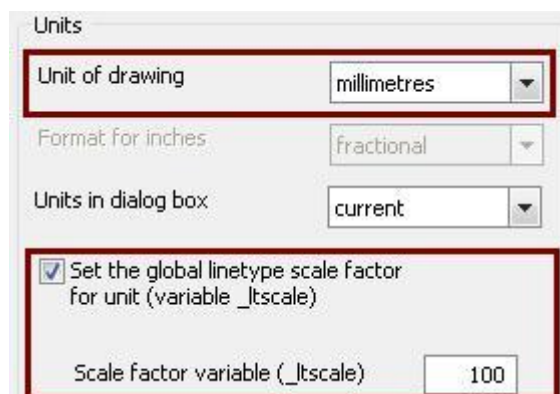

Drawing housing distribution board project

Adding front page

We start the project with inserting a front page. To do this, click on the *Frames and tables* icon located on the *CADprofi – Electrical* toolbar.

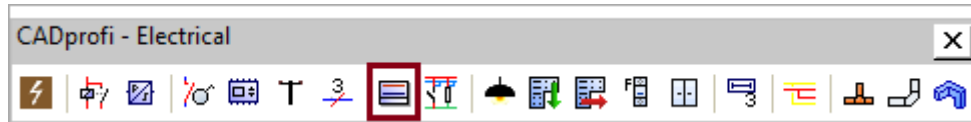

Then from the drop-down list *ISO* -> *Frames* we select the *front page* ...

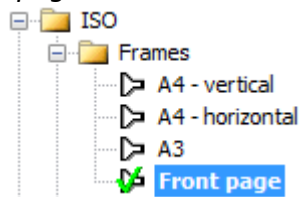

... and enter the data. The date field is filled in automatically. We set the scale to 1 and insert the front page into the drawing by using the *Insert* button.

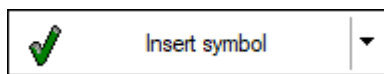

Owner	CADprofi ul. Struga 26/28 26-600 Radom
	ELECTRICAL DOCUMENTATION
Subject	Housing distribution board project
Investor	--
Designed by	John Kowalski
Comments	
Date	28.04.2021
Number of sheets	4

User symbols

CADprofi program has an extensive library of symbols compliant with national and international standards. User can easily add his own symbols or products at any time. To do this, click the *Modular units* button in the *CADprofi - Electrical* toolbar.



From the drop-down list *Miniature circuit breakers* we select *Miniature circuit breakers 1P*, and then *Characteristics B*. From this category we select the B10 overcurrent circuit breaker and click the *Copy* button, thanks to which the selected product (object) will be copied to the *User* category. In the next step, we will describe the technical and identification data of the copied product (object). To do this we click the *Edit* button and in the newly

opened window we define the parameters of the product (object): article, catalog number (reference), type and name of the manufacturer.

Specify all parameters

Parameter	Value
Name (Attrib)	Miniature circuit breaker 1P
Article	CLS6-B10
Product-type	EATON
Connectors data	
Ingress Protection	
DIN modules	1
N	
Reference	269608
Current I	10 A
...	

Products (objects) that we have created will appear at the bottom of the list, in the *User* category:

The screenshot shows the 'Modular units' software interface. On the left is a tree view of product categories. The main area displays a table of products with columns for Article, A, B, C, and D. A red box highlights the 'User' category, which contains a sub-category 'EATON' with the product 'CLS6-B10' selected. Below the table are configuration options for the selected product, including 'View and insertion point' (set to 2D), 'Labels' autonumbering' (checked), and fields for Article (CLS6-B10), Manufacturer (EATON), and Reference (269608). A diagram of the circuit breaker is shown in the bottom left corner.

Article	A	B	C	D
B6	1.80	8.60	4.50	
B10	1.80	8.60	4.50	
B13	1.80	8.60	4.50	
B16	1.80	8.60	4.50	
B20	1.80	8.60	4.50	
B25	1.80	8.60	4.50	
B32	1.80	8.60	4.50	
B40	1.80	8.60	4.50	
B50	1.80	8.60	4.50	
B63	1.80	8.60	4.50	
User				
EATON				
CLS6-B6-DP	1.80	8.60	4.50	
CLS6-B16-DP	1.80	8.60	4.50	
CLS6-B10	1.80	8.60	4.50	
ABB				
S201-B6	1.80	8.60	4.50	
S201-B10	1.80	8.60	4.50	
S201-B16	1.80	8.60	4.50	

When working with the scheme creator, we can use products that we have prepared earlier with a specific manufacturer's name. We can also use "no name" products, where the contractor will decide on the manufacturer's choice.

Power distribution schemes creator – inserting symbols

Now we will move on to the design of the power distribution scheme. To do this, we click the *Scheme creator and templates* button on the *CADprofi - Electrical* toolbar.



Scheme creator available in CADprofi program allows user to quickly prepare the project, allowing the designer to focus only on the selection of products, not on manual drawing.

We will start working with the creator from the checking general settings:

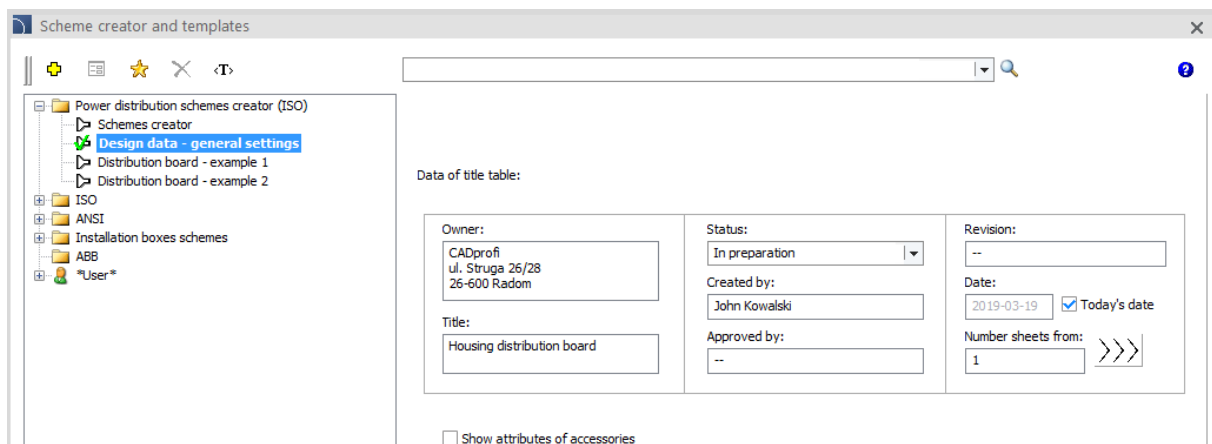

Scheme creator allows user to select products available in the modular apparatus library and place them in specific positions in the scheme. We will start our work by inserting a 3P switch disconnector

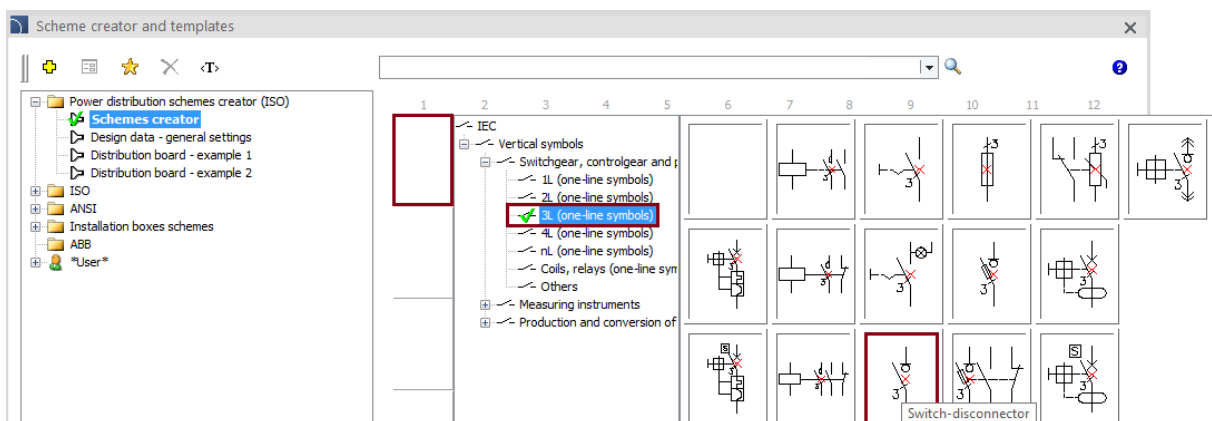

In the newly opened window, select one of the available switch disconnector types. User-created types are also listed.

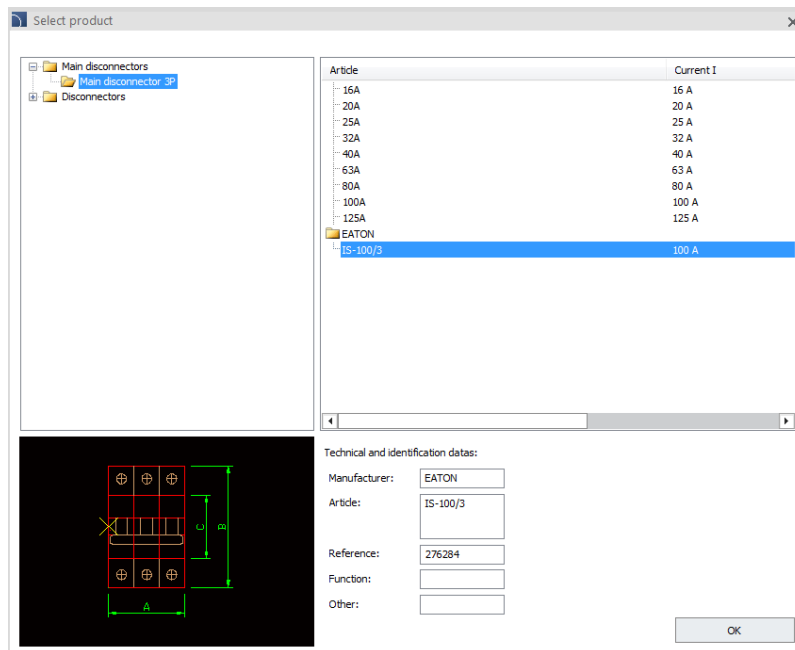

In the next field, we will insert a surge diverter

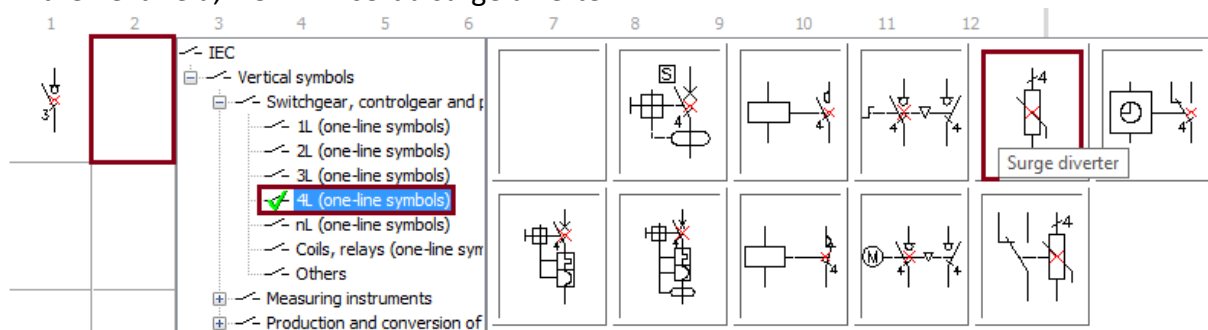

In the third field, we will insert a fuse switch-disconnector, which will serve as a protection for the signal lamp.

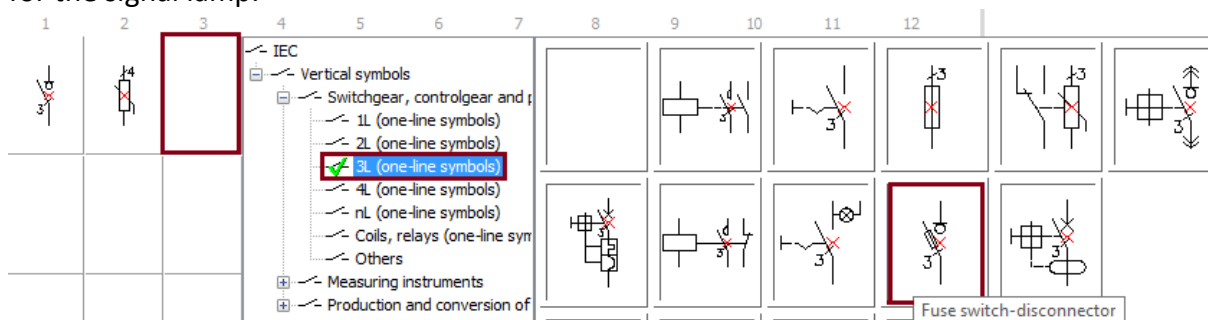

In the newly opened window we can select one of the available types of switch disconnector and describe its technical parameters. We can also choose the size of the fuse link, e.g. 10x38gG6Ax3.

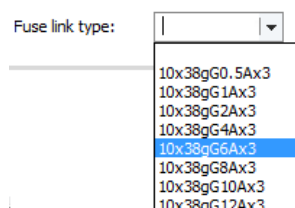

In the field just below the fuse switch disconnector, we will place a triple indicator lamp.

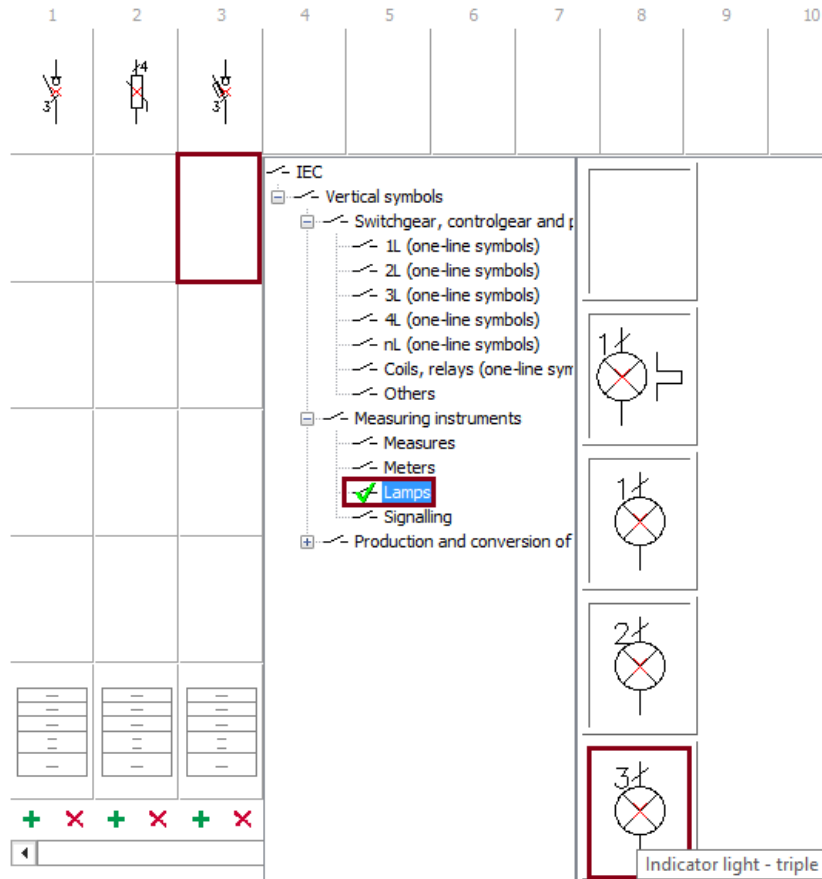

We will insert several socket circuits in the next steps.

We will start by inserting a 4P residual current disconnector.

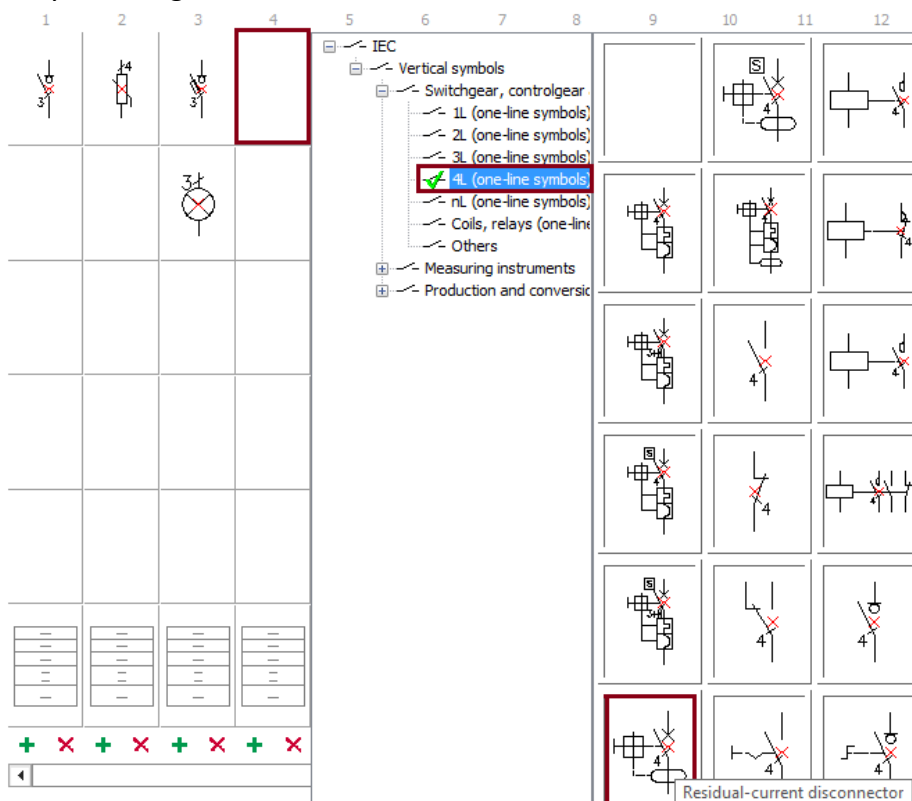

Power distribution schemes creator – copying symbols

Program has a convenient system for copying symbols inserted into the schemes creator. To begin with, we will insert a 1P *modular circuit breaker* as we continue our project.

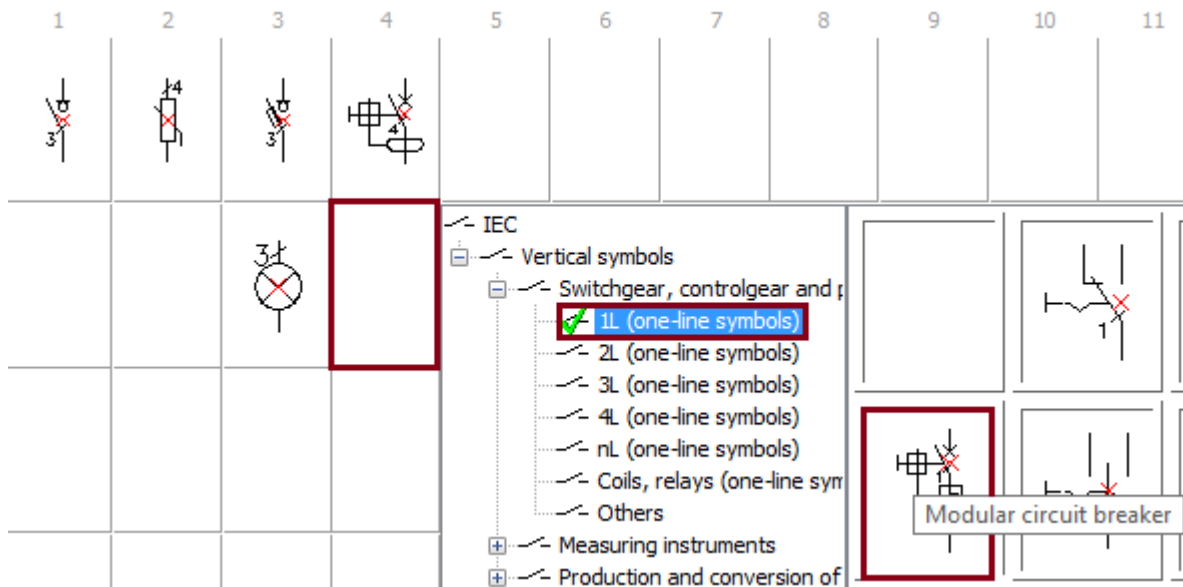

Then right-click on the previously inserted symbol of the modular circuit breaker and click the *Copy symbol* button.

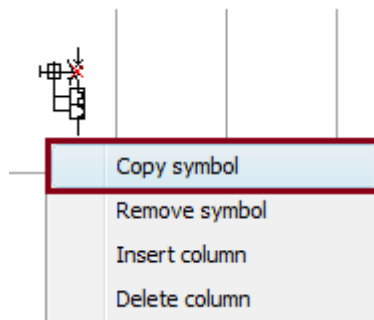

In the next step, we copy the symbol of the modular circuit breaker to the next fields on the scheme.

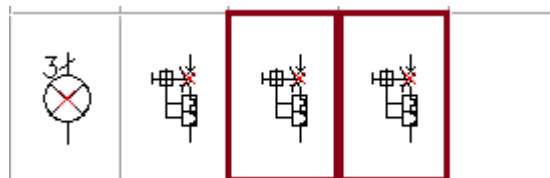

We end the copying process by right-clicking in any field of the scheme, and then clicking the *Finish copying* button. The copying process can also be terminated by pressing the *ESC* button.

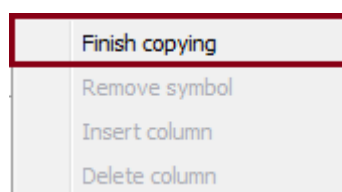

Now we will add a lighting circuit to our project. We will start by inserting a 2P residual current device.

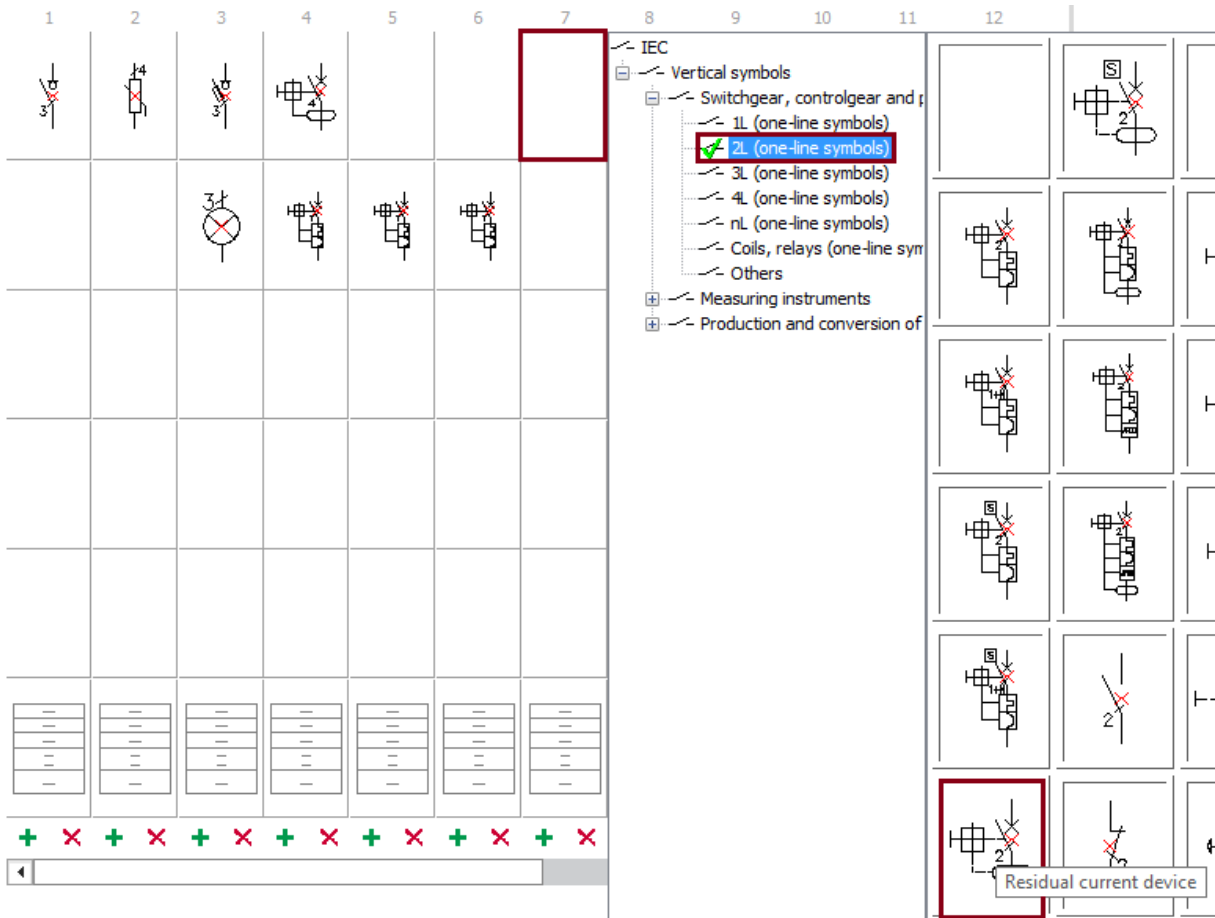

Afterwards we will insert a 1P modular circuit breaker into the diagram just below the RCD. This time, we will choose the *CLS6-B10* product previously prepared by us as the type.

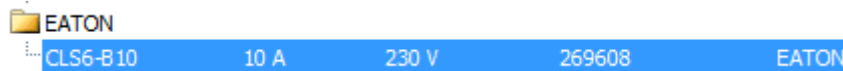

After inserting the modular circuit breaker, we will copy it into the next two fields by using the *Copy* option. Our project will look like this:

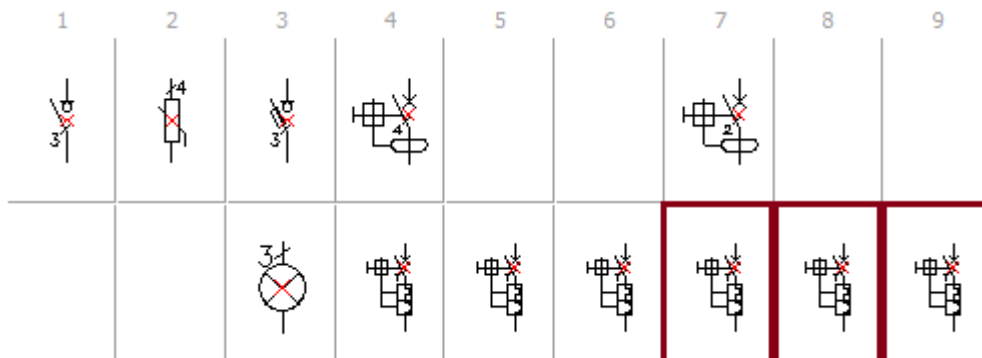

Power distribution schemes creator – inserting new columns

We will start the continuation of our project by inserting three new columns, thanks to which we will have a place for inserting more socket circuits. To do this, we will click the *Insert column* button three times.

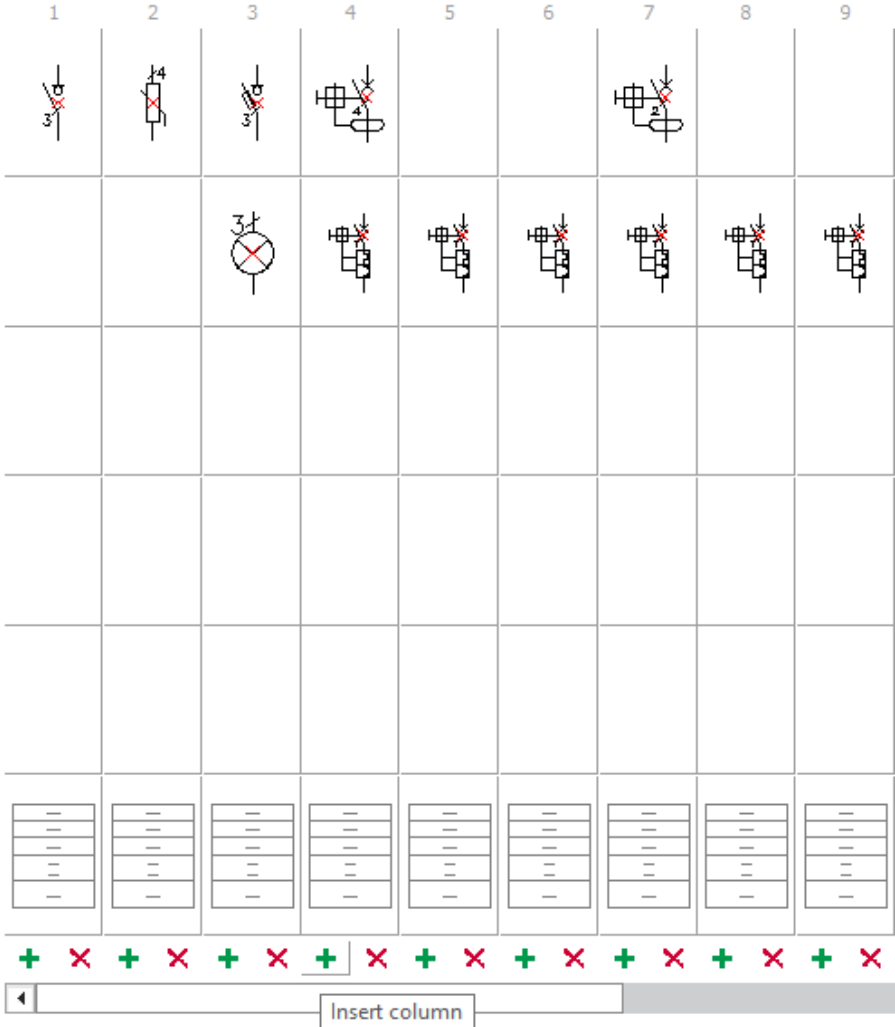

Afterwards we will insert a *residual current circuit breaker with overcurrent protection* into the project.

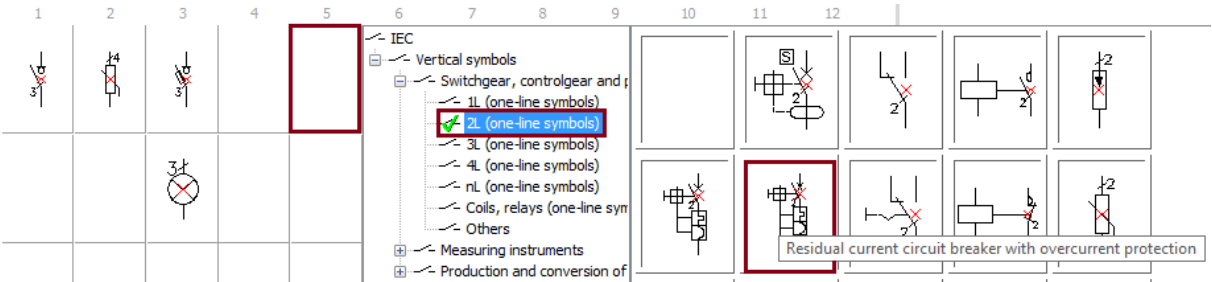

In the next step, we will use the Copy option to copy the *RCD with overcurrent protection* to the next field. Thanks to this, we will achieve the following effect:

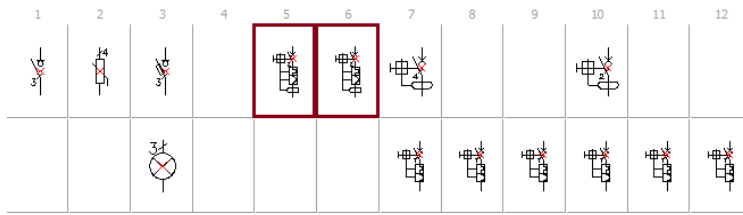

Our next step will be to design the furnace power circuit. We will start by inserting a *4P residual current disconnecter*.

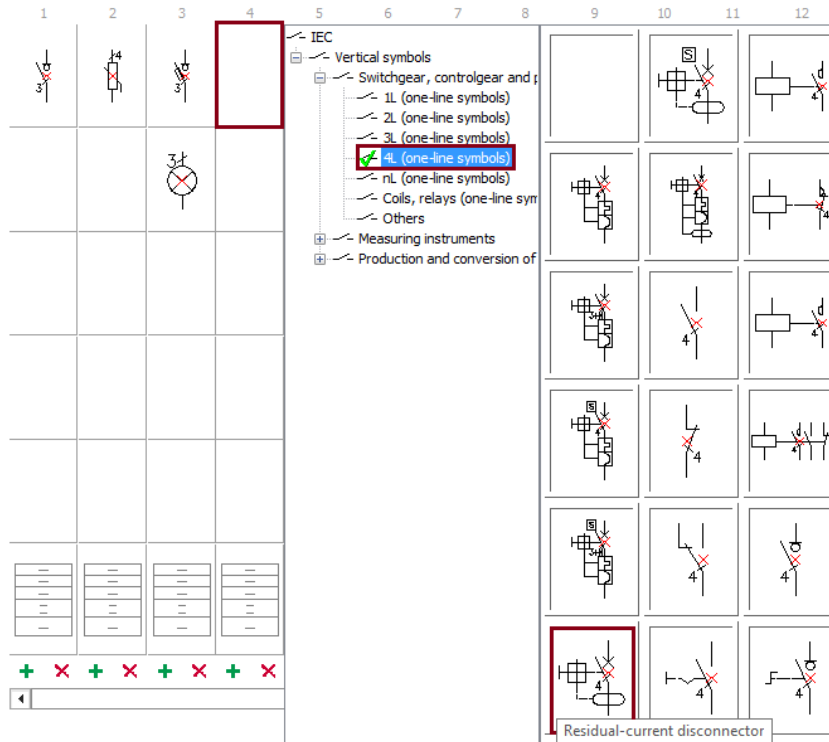

We will insert an *automatic phase switch* as a power supply for the furnace.

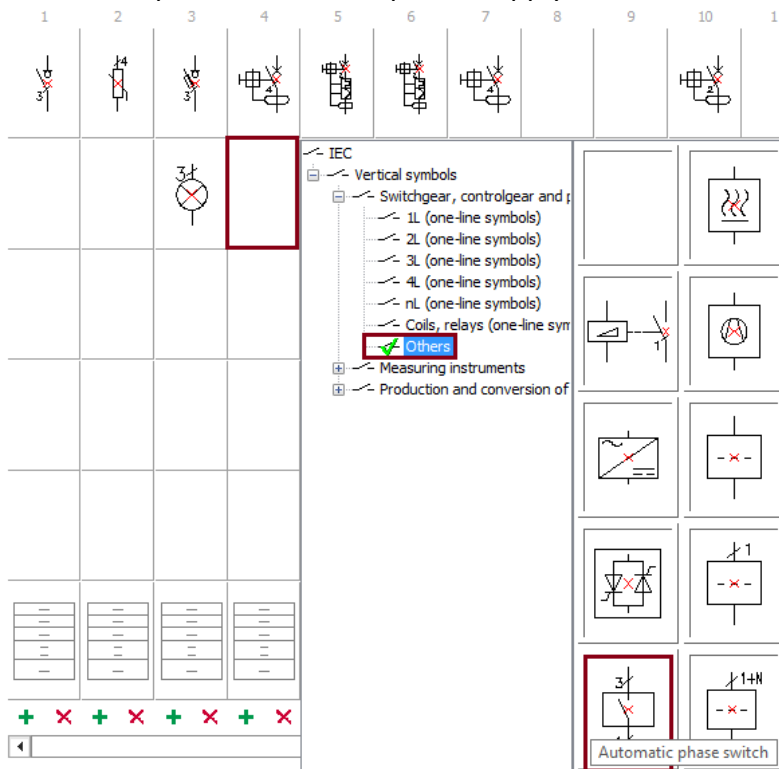

In the next step we will protect our circuit by copying the previously inserted modular circuit breaker 1P.

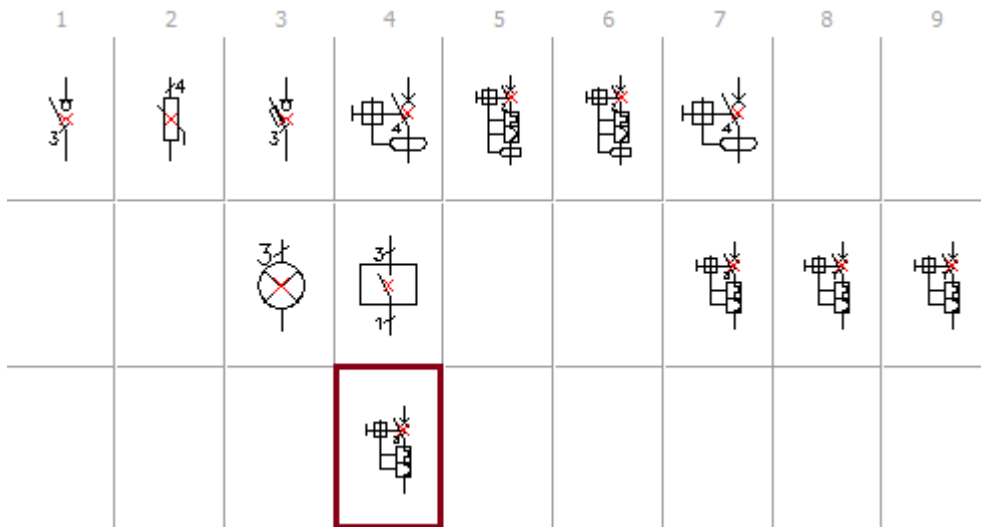

Afterwards, we will insert a circuit that powers an induction hob into our project. To do this, we will use the *Insert column* option again.

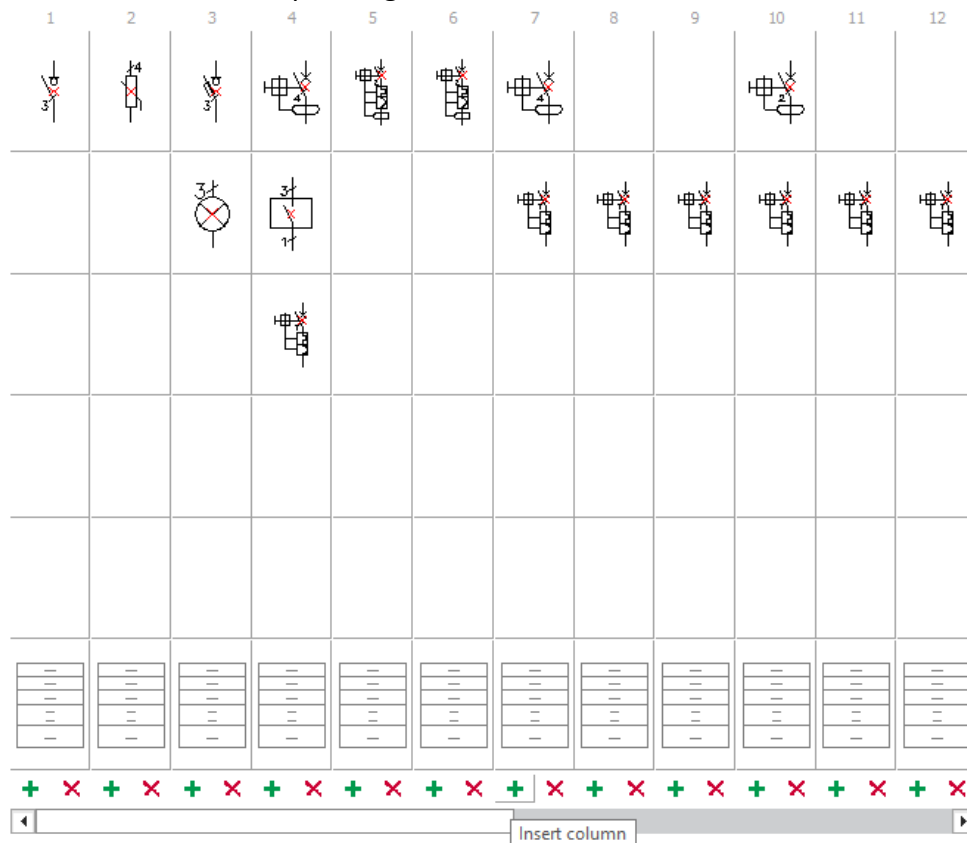

By using the *Copy* option, we will copy the *4P residual current circuit disconnecter*.

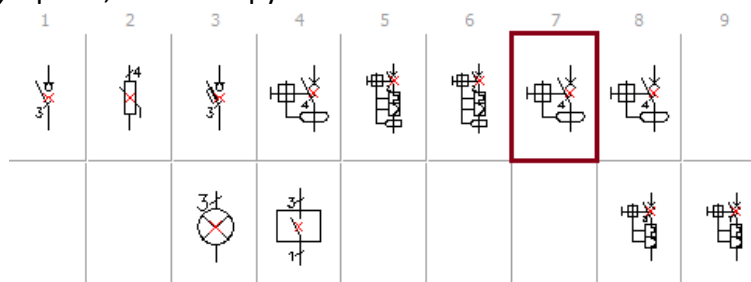

Afterwards we will protect the circuit with a 3P circuit breaker.

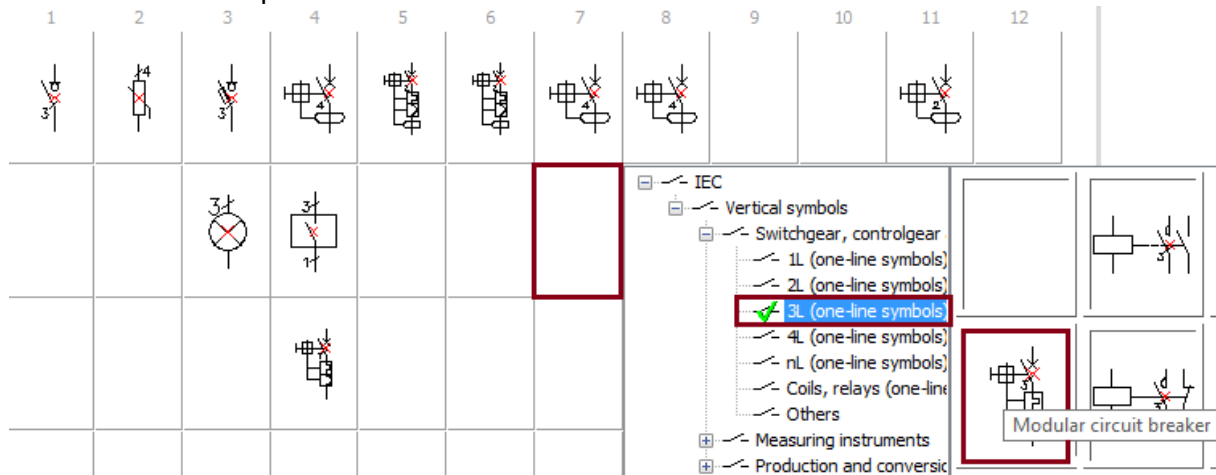

Power distribution schemes creator – describing circuit tables

Schemes creator allows user to describe the technical data of each individual circuit. To describe the circuit table, first click the circuit table button at the bottom of the schemes creator.



Then, in the newly opened window, we will enter the electrical circuit data. In our case it will be:

The image shows a dialog box titled 'Electrical circuit data'. It contains the following fields:

- Name of circuit / receiver: Main
- Type and section of a cable: NYY-J 5x6mm²
- Power [kW] / Current [A]: 32A
- Description: (empty field)
- Circuit number: (empty field)

At the bottom of the dialog box is an 'OK' button.

We describe each successive circuit table in the same way. We can describe them ourselves or use the descriptions below:

Circuit 2

Name of circuit/receiver: Overvoltage protection

Circuit 3

Name of circuit/receiver: Signal lamps

Circuit 4

Name of circuit/receiver: Furnace socket

Type and section of a cable: NYM-J 3x2.5mm²

Power [kW] / Current [A]: 2kW

Description: Boiler

Circuit 5

Name of circuit/receiver: Oven socket

Type and section of a cable: NYM-J 3x2.5mm²

Power [kW] / Current [A]: 2,5kW

Description: Kitchen

Circuit 6

Name of circuit/receiver: Fridge socket

Type and section of a cable: NYM-J 3x2.5mm²

Power [kW] / Current [A]: 0,4kW

Description: Kitchen

Circuit 7

Name of circuit/receiver: Induction hob socket

Type and section of a cable: NYM-J 5x4mm²

Power [kW] / Current [A]: 9kW

Description: Kitchen

Circuit 8

Name of circuit/receiver: Work socket

Type and section of a cable: NYM-J 3x2.5mm²

Power [kW] / Current [A]: 2,5kW

Description: Kitchen

It is worth remembering that data from circuit tables, just like symbols, can be easily copied. When describing subsequent circuits, it is worth using this command, thanks to which we will speed up the work. Right-click on the circuit table (e.g. working socket) and copy the data to the next table. Then, by clicking on the circuit table, you can easily edit the data.



Circuit 9

Name of circuit/receiver: Work socket

Type and section of a cable: NYM-J 3x2.5mm²

Power [kW] / Current [A]: 2kW

Description: Bathroom

Circuit 10

Name of circuit/receiver: Washing machine socket

Type and section of a cable: NYM-J 3x2.5mm²

Power [kW] / Current [A]: 2,5kW

Description: Bathroom

Circuit 11

Name of circuit/receiver: Lighting circuit

Type and section of a cable: NYM-J 3x1.5mm²

Power [kW] / Current [A]: 1kW

Description: Kitchen

Circuit 12

Name of circuit/receiver: Lighting circuit

Type and section of a cable: NYM-J 3x1.5mm²

Power [kW] / Current [A]: 1kW

Description: Bathroom

Circuit 13

Name of circuit/receiver: Lighting circuit

Type and section of a cable: NYM-J 3x1.5mm²

Power [kW] / Current [A]: 1kW

Description: Bathroom

Finally, we will design a power supply for the external lighting of the building. To do this, we will copy the residual current device and the modular circuit breaker.

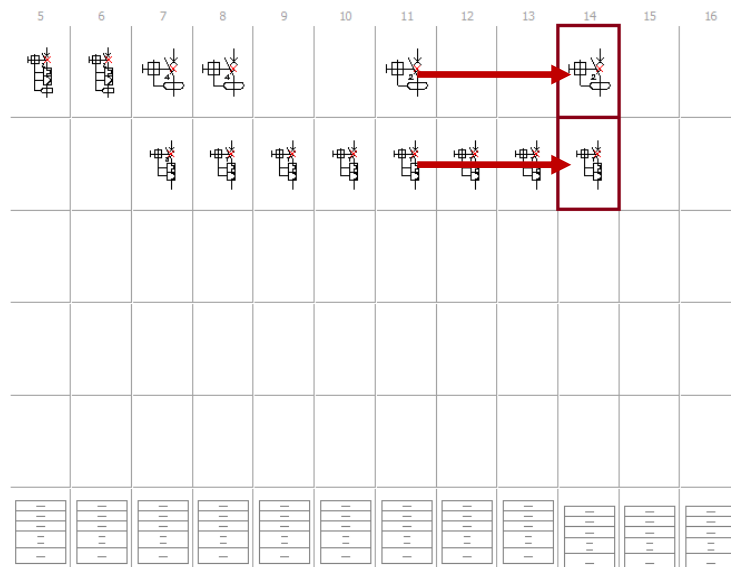

We will not describe the circuit tables on purpose, we will do it in the next chapter, showing the program editing commands.

Power distribution schemes creator – saving scheme

CADprofi scheme creator allows user to quickly save and load the project. The following options are used for this purpose:

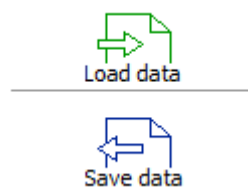

After clicking the *Save data* button, a new window will appear allowing us to save the project.

File name:	Tutorial_Electro
Save as type:	Data files (*.cpeproj)

When loading projects, it is possible to attach a previously saved project directly after the last symbol by using the *Add the data loaded after the last symbol* option.

After saving the project, it is time to insert it directly into the drawing. To do this, we select below options and we click the *Insert* button.

<input checked="" type="checkbox"/> Draw 'N' line from top	Without terminals
<input checked="" type="checkbox"/> Divide schemes into worksheets	Products numbering: By products
<input checked="" type="checkbox"/> Insert table with a drawing frame	Number circuits from: 1
Sheet size: A4 - ISO	Insert
Scheme area: 252 x 125	

Our project (with the above options selected) after insertion will look like this:

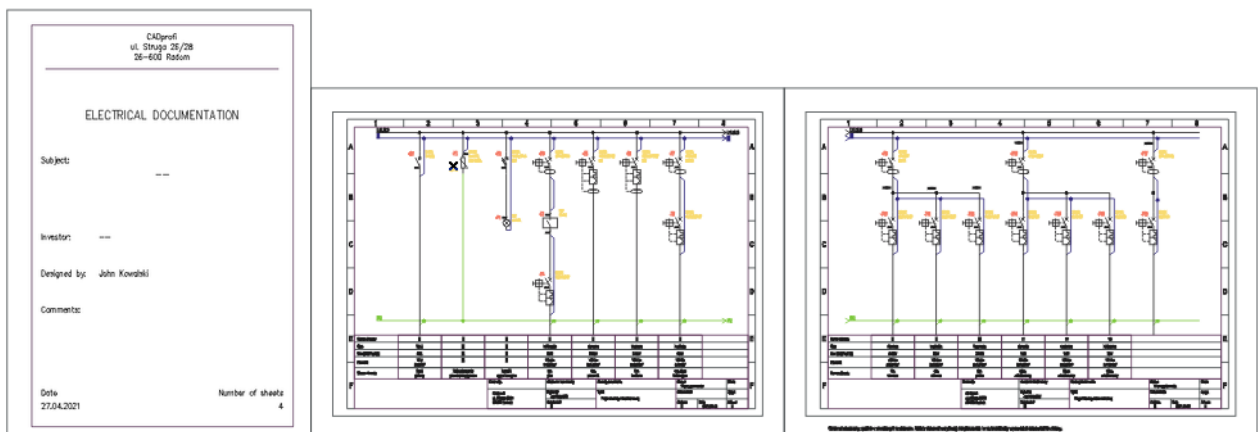

Editing scheme – editing symbols

We didn't describe the last circuit table. We can do it at any time by using CADprofi editing commands.

To do this, we click the *Edit symbols* button on the *CADprofi - Edit* toolbar.



Afterwards we click directly on the undescribed table...

12	13	14
Bathroom	Boiler	--
1kW	1kW	--
NYM-J 3x1.5mm ²	NYM-J 3x1.5mm ²	--
Lighting socket	Lighting socket	--

... and we enter the missing data in the newly opened window:

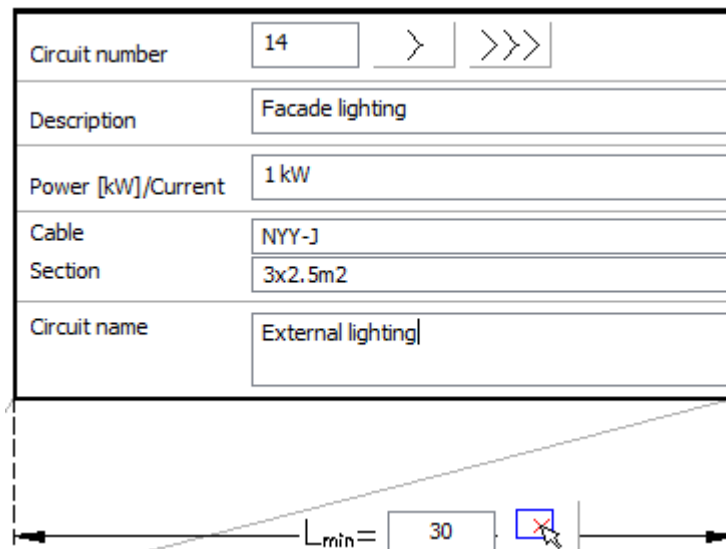
A screenshot of the CADprofi - Edit dialog box. The dialog box has several fields: 'Circuit number' (14), 'Description' (Facade lighting), 'Power [kW]/Current' (1 kW), 'Cable' (NYY-J), 'Section' (3x2.5m²), and 'Circuit name' (External lighting). Below these fields is a section for 'L_{min}' with a value of 30 and an 'Apply' button highlighted with a red box.

After filling in the data, we click the Apply button.

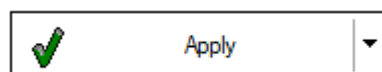

Designing an external circuit control scheme - frames and tables

We will start designing the external circuit control scheme from inserting a frame. To do this, we click the *Frames and tables* button on the *CADprofi - Electrical* toolbar.

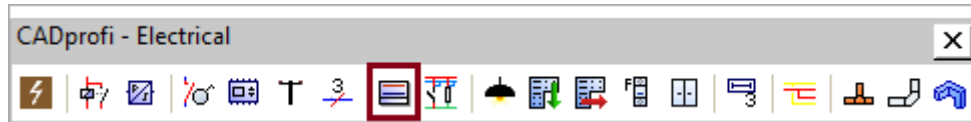

Afterwards we choose *ISO -> Frames -> A4 - horizontal*. In frame options, we select the following options: *Reference grid* and *Untrimmed size*. Then we click the *Insert* button.

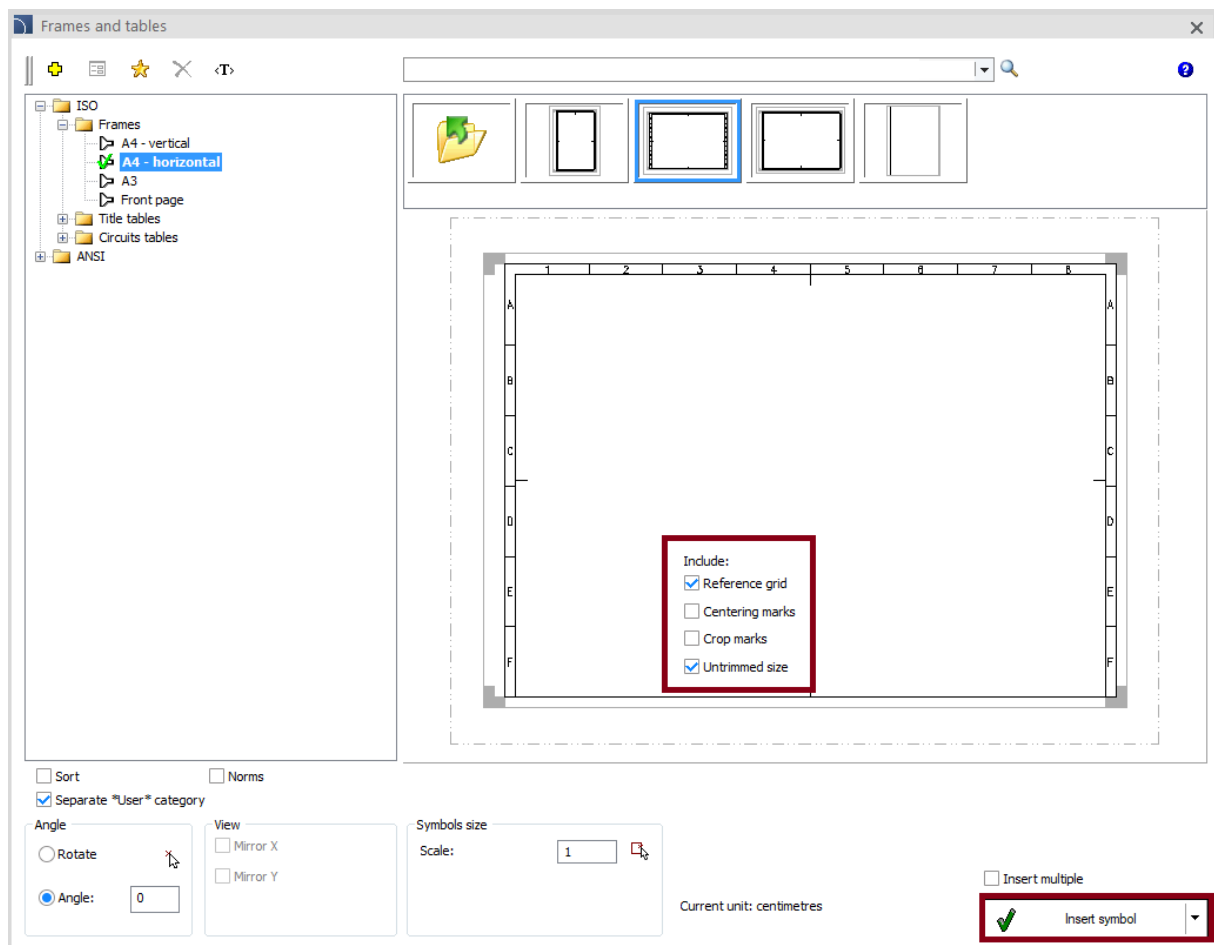

In the next step, we will insert a title table. To do this, we click the *Frames and tables* button on the *CADprofi - Electrical* toolbar again.



Afterwards we choose *ISO -> Tables -> A4 table - ISO 1*. We fill in the data, as title we enter *Control circuit - external lighting*.

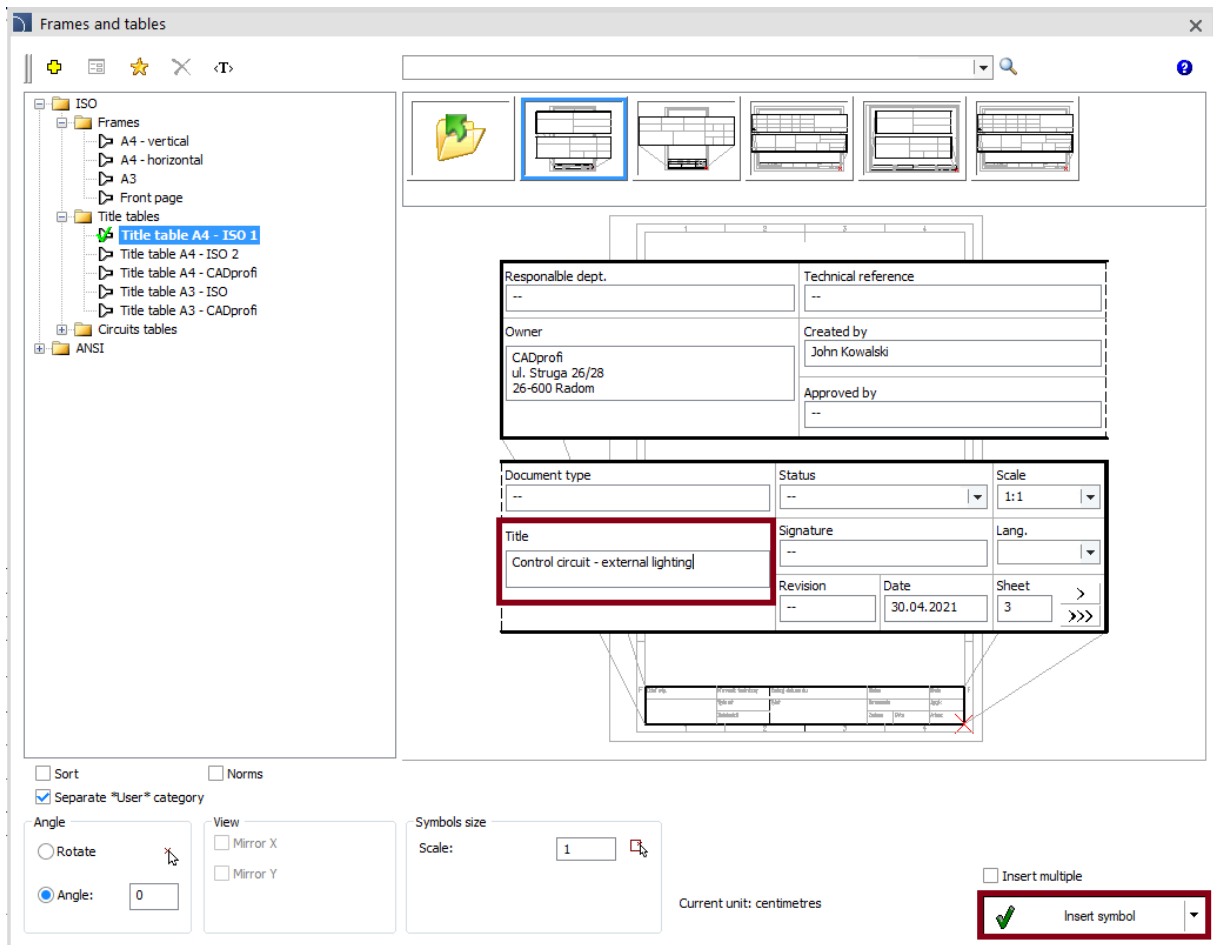

We click the *Insert* button and we insert the table.

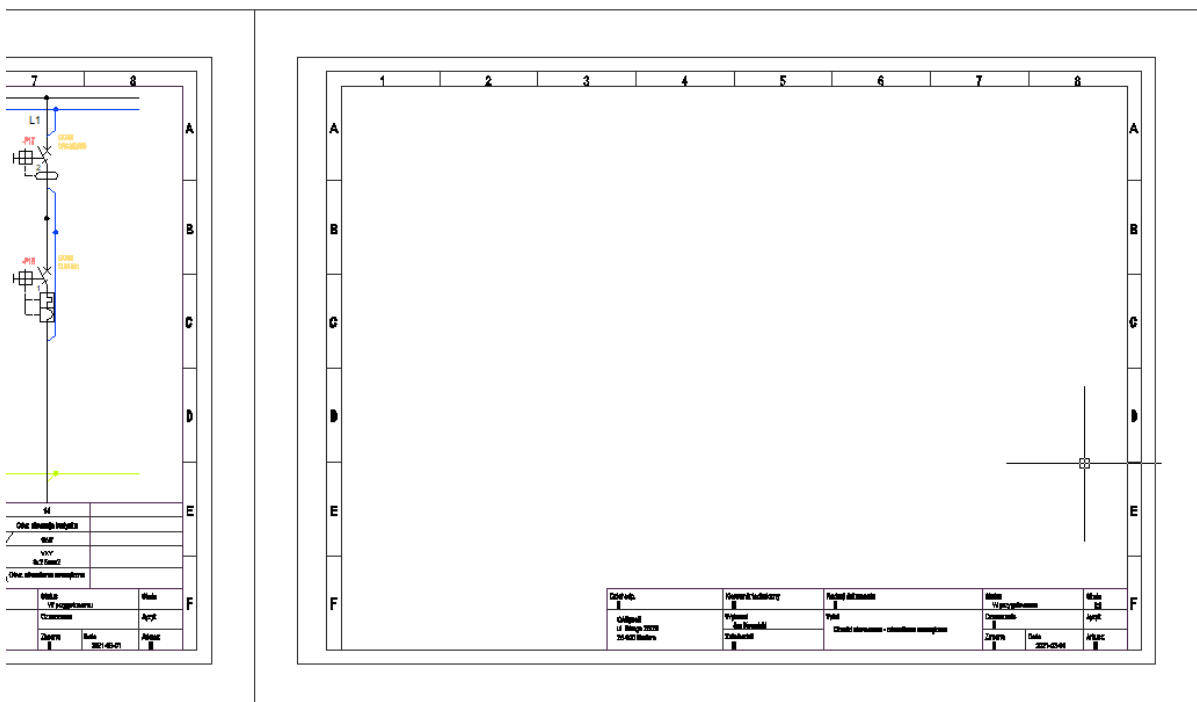



Designing an external circuit control scheme – lines templates

In the next step, we will insert potential lines. To do this, we click the *Scheme creator and templates* button on the *CADprofi - Electrical* toolbar.

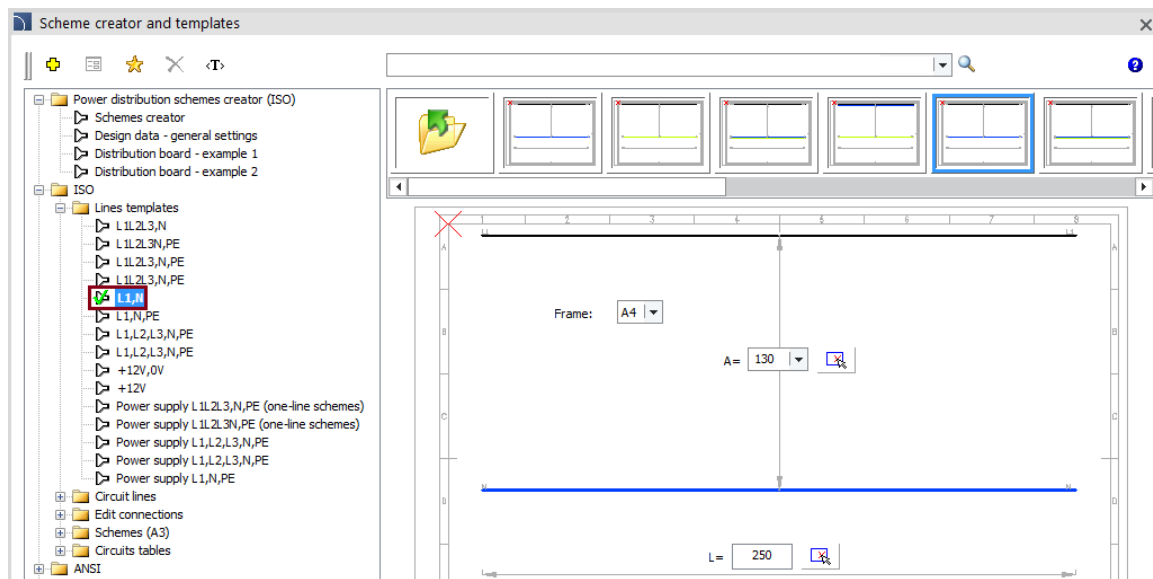

Afterwards we select *ISO* -> *Lines templates* -> *L1, N*.



We select the frame as A4 and dimension A as 130. Dimension L (i.e. the width of the potential line) we will determine directly from the drawing. To do this, we click the  button and then we define the L dimension by indicating two consecutive points P1 and P2.

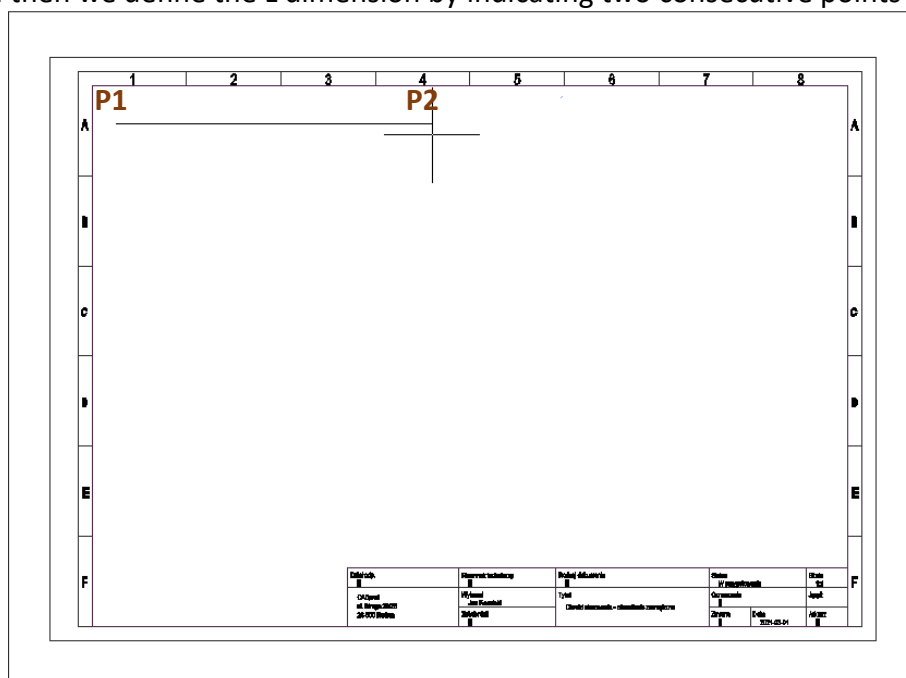

After determining both points, the potential line selection window will appear again, this time however, the L dimension will have the value that was determined by us.

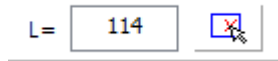

We click the *Insert* button and we insert the potential line directly into the drawing.

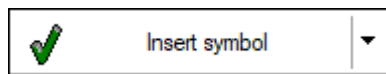

We insert the potential line in the upper left corner (insertion point).

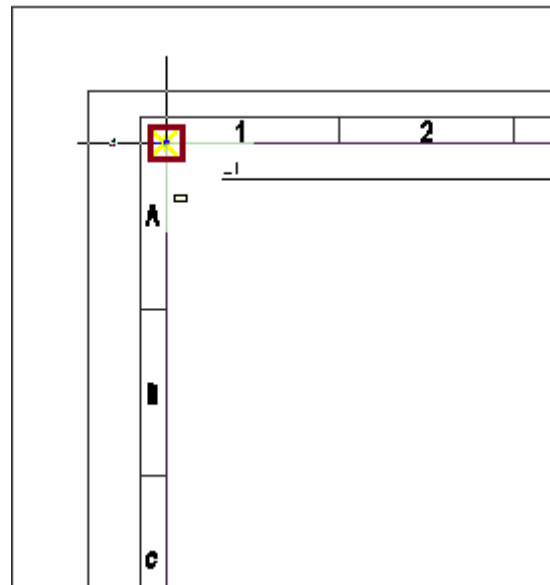

Designing an external circuit control scheme – circuit lines

The next step will be to insert circuit lines. To do this, we click the *Lines, cable trays - schematics* button on the *CADprofi - Electrical* toolbar.



In the dialog window, we select the L1 cable (by double-clicking or selecting it and pressing the arrow button).

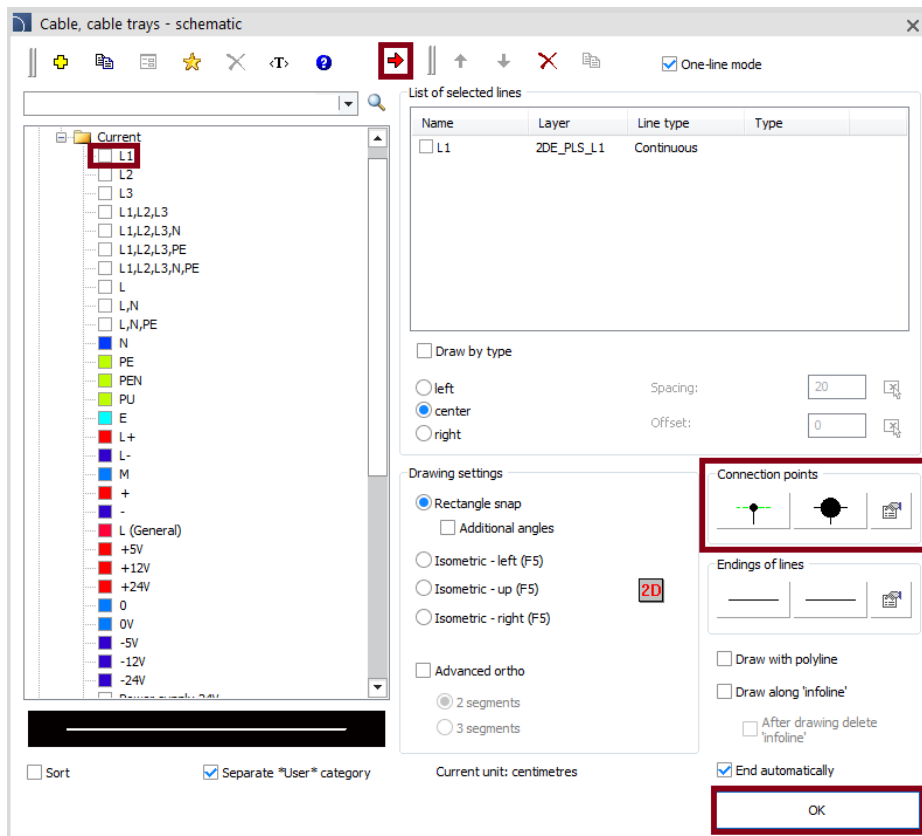

We select the one-line drawing mode One-line mode

To insert a *connection symbol* at the connection points, click the *Connection points* button and set the required options in the dialog box.

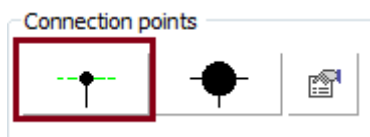

In the settings, we select the *Connection type* to *Always*.

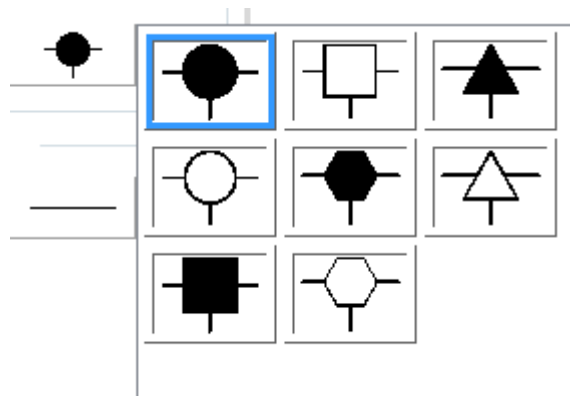

We set the scale as 1.5.

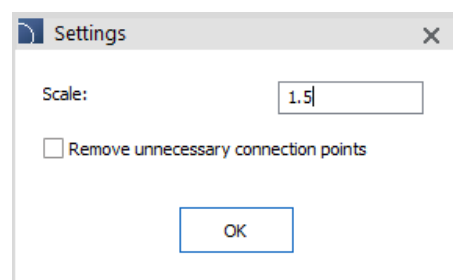
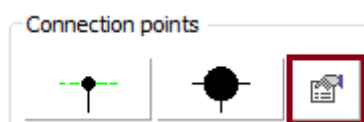

Afterwards we click the *OK* button and insert our line directly into the drawing. When inserting a line, we first click on the P1 point, and then on the P2 point:

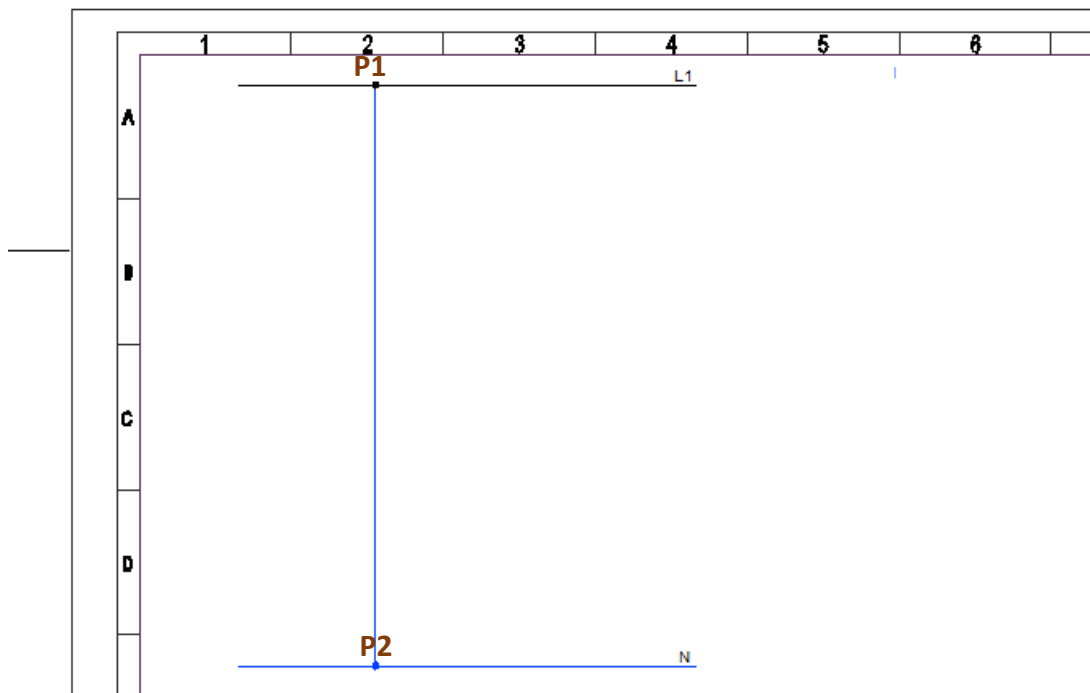

In the next step, we will insert two more lines. To do this, click the *Lines, cable trays - schematics* button on the *CADprofi - Electrical* toolbar again. We can also use the CPX keyboard shortcut - this shortcut runs the previously used CADprofi command.



We insert first the *L1* line into the drawing, and then the *N* line. Both lines will be inserted into the previously inserted circuit no. 14 - *Outdoor lighting*.

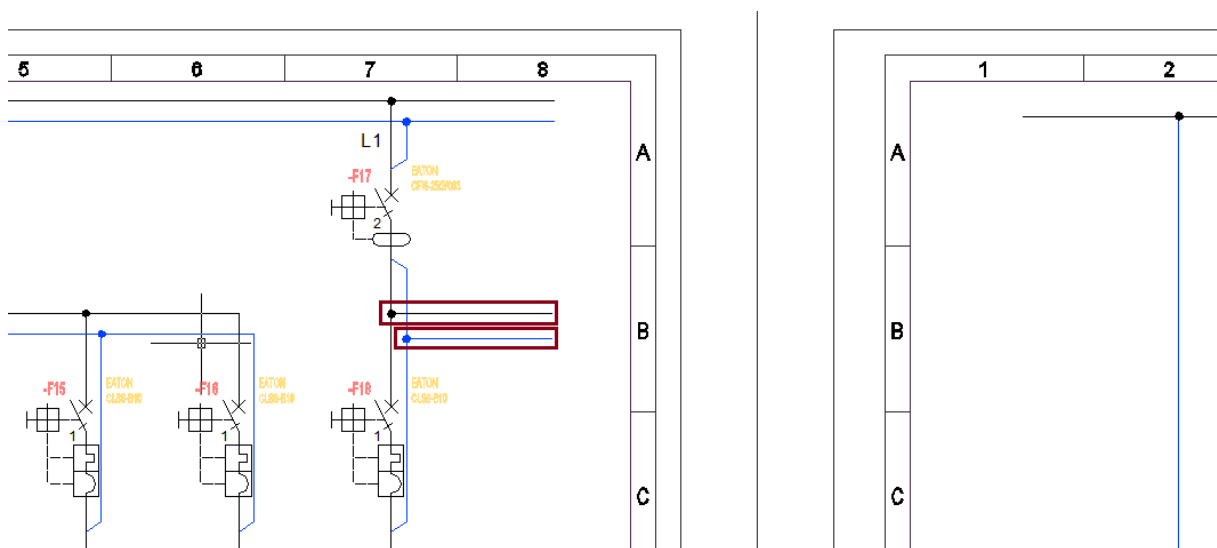

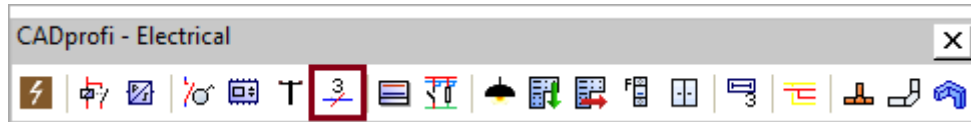

Describing and editing the scheme -

In the next step, we will insert the addresses of the potential lines. We click the *Descriptions* button and then select *Address Symbol IEC* from the *Automatic sign* category.

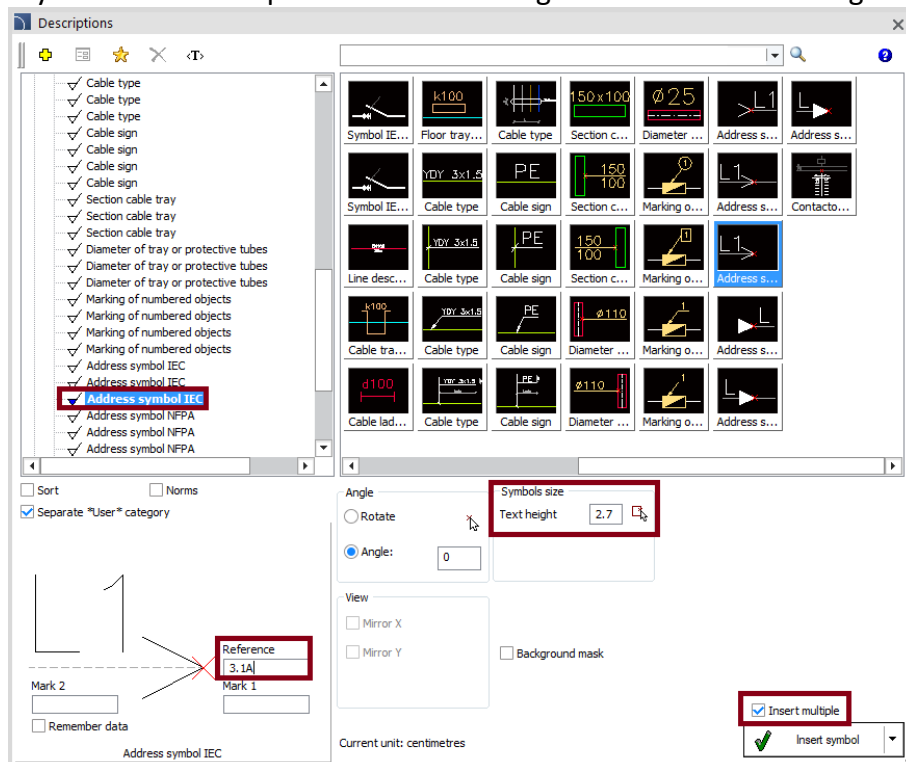

We set the height of the text to 2.7 and we enter the reference as 3.1A. Before clicking the Insert button, select the Insert multiple option *Insert multiple* thanks to which we will insert the Address Symbols in several places without having to run the command again.



We put *Address symbols* in two places. Then by using the *Edit symbols* command  we click on the second Address symbol and we modify the reference to 3.1E.

Reference
3.1E

After modifying the marking, we click the *Apply* button.

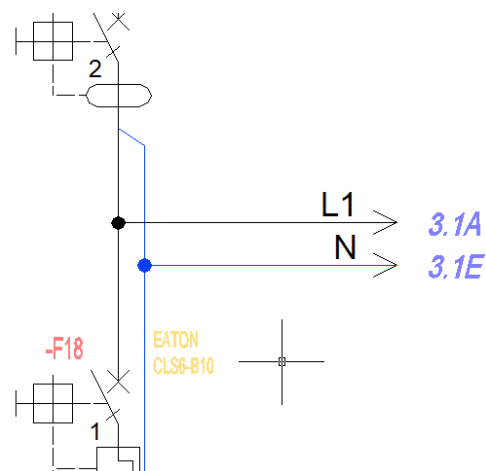

In the next step, we will insert two more Address symbols. To do this, we click the *Insert similar object* button  located on the *CADprofi - Edit* toolbar.



Afterwards we will select one of the previously inserted Address symbols. Thanks to the *Insert similar object* command, program will open the selected symbol in its original dialog window. Thanks to this, we can quickly select, for example, a symbol with a modified description or an alternative symbol.

In our case, we will select *Address Symbol IEC* again, but this time it will be an alternative symbol variant. We will enter *2.8B* as the reference.

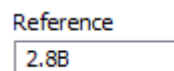

We will also select the *Insert multiple* option because we will insert the symbol in two places in the scheme.

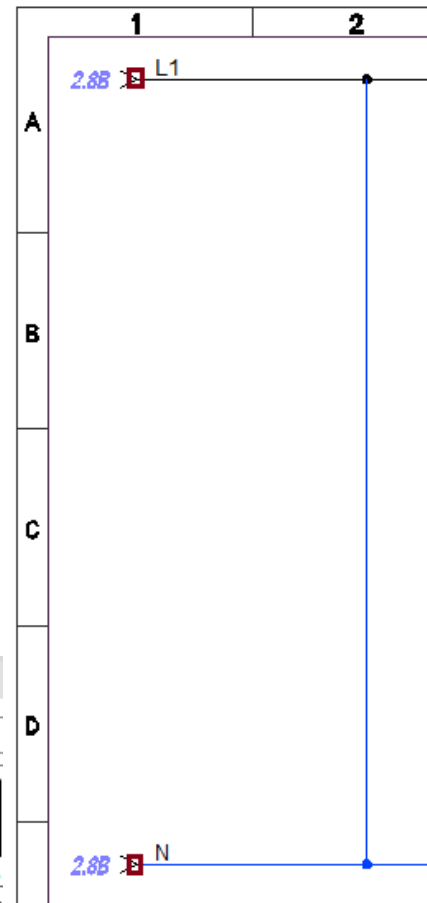
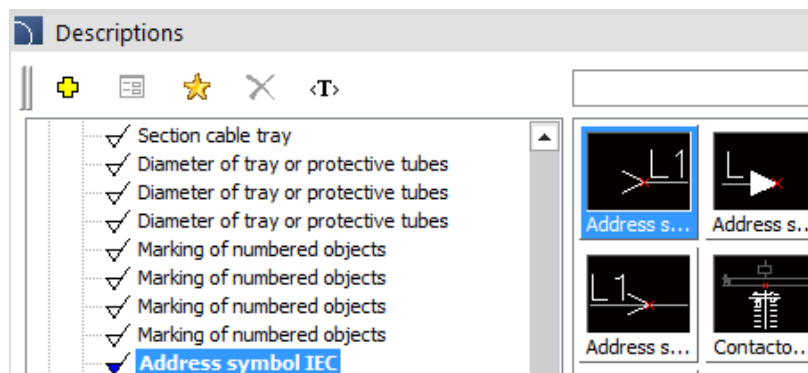

In the next step, we will describe the phases of the individual circuits. We will go to the *Description* command and then select *Objects numeration* from the *Automatic sign* category.



We select the *Numeration* option Numeration and we enter the first number as L1. Since we are going to number the phases of several circuits, we also select the *Insert multiple* option.

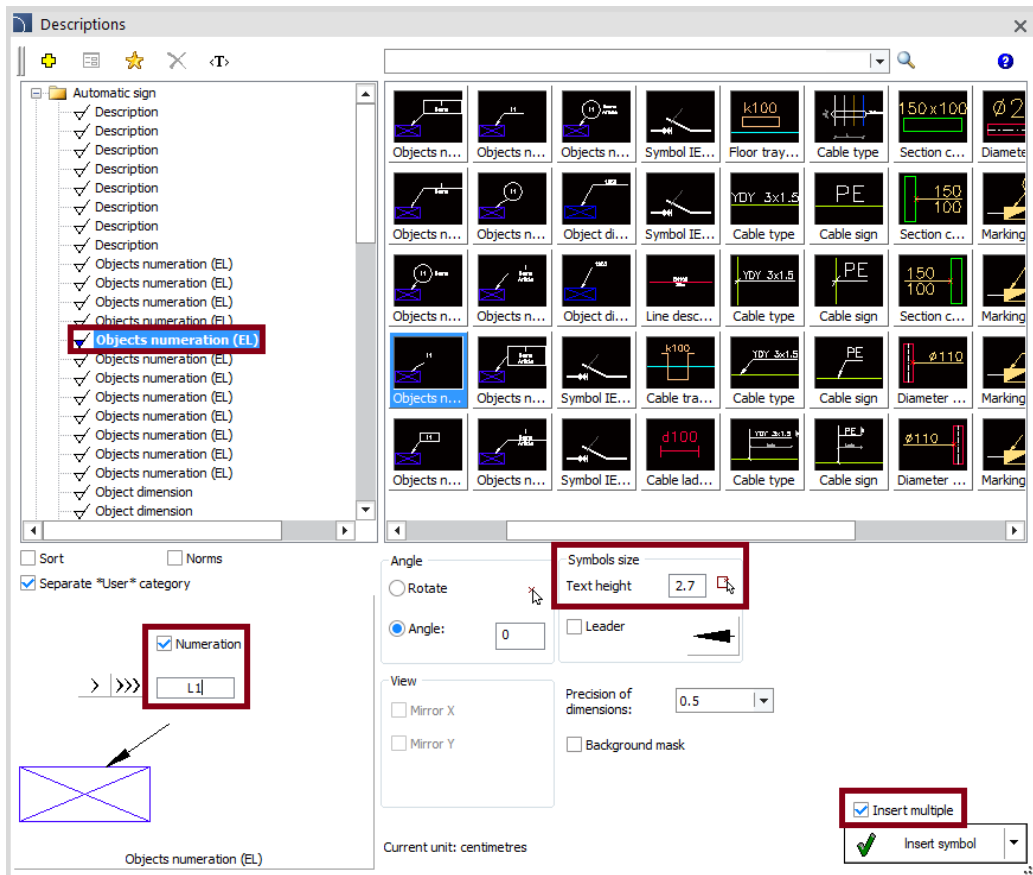

Then click on each individual circuits describing the first, second and third phase.

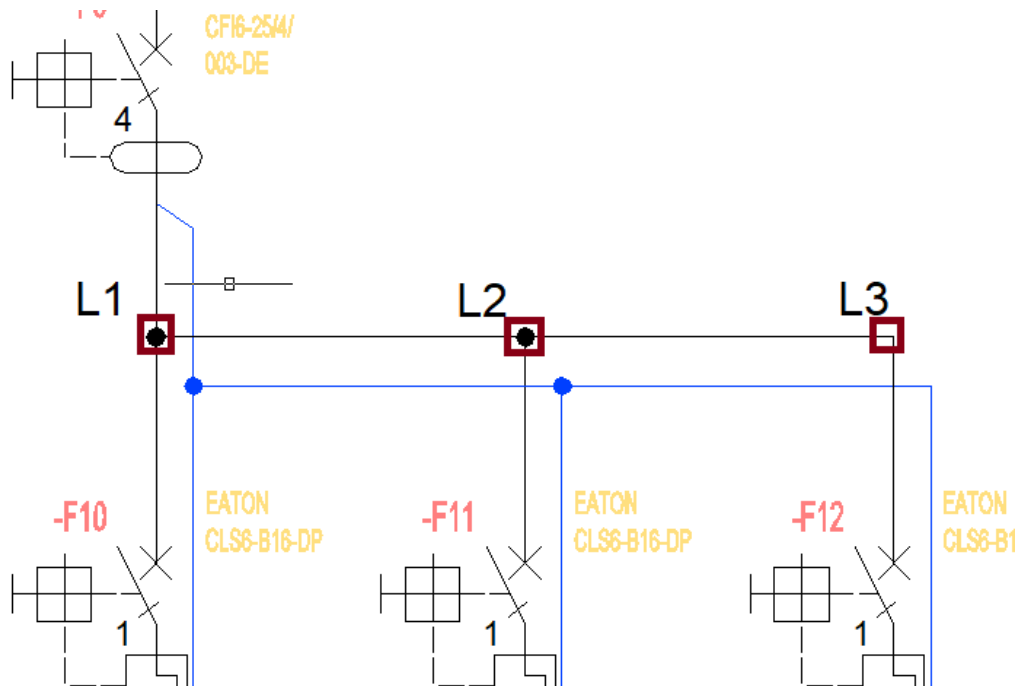

Designing an external circuit control scheme – inserting symbols

In the next step, we will design a control scheme for the building's outdoor lighting circuit. To do this, we click the *Modular units* button on the *CADprofi - Electrical* toolbar.



Afterwards we will insert a time switch. There are many products in the program, the most convenient way to find the right one is to use the *Search* option.



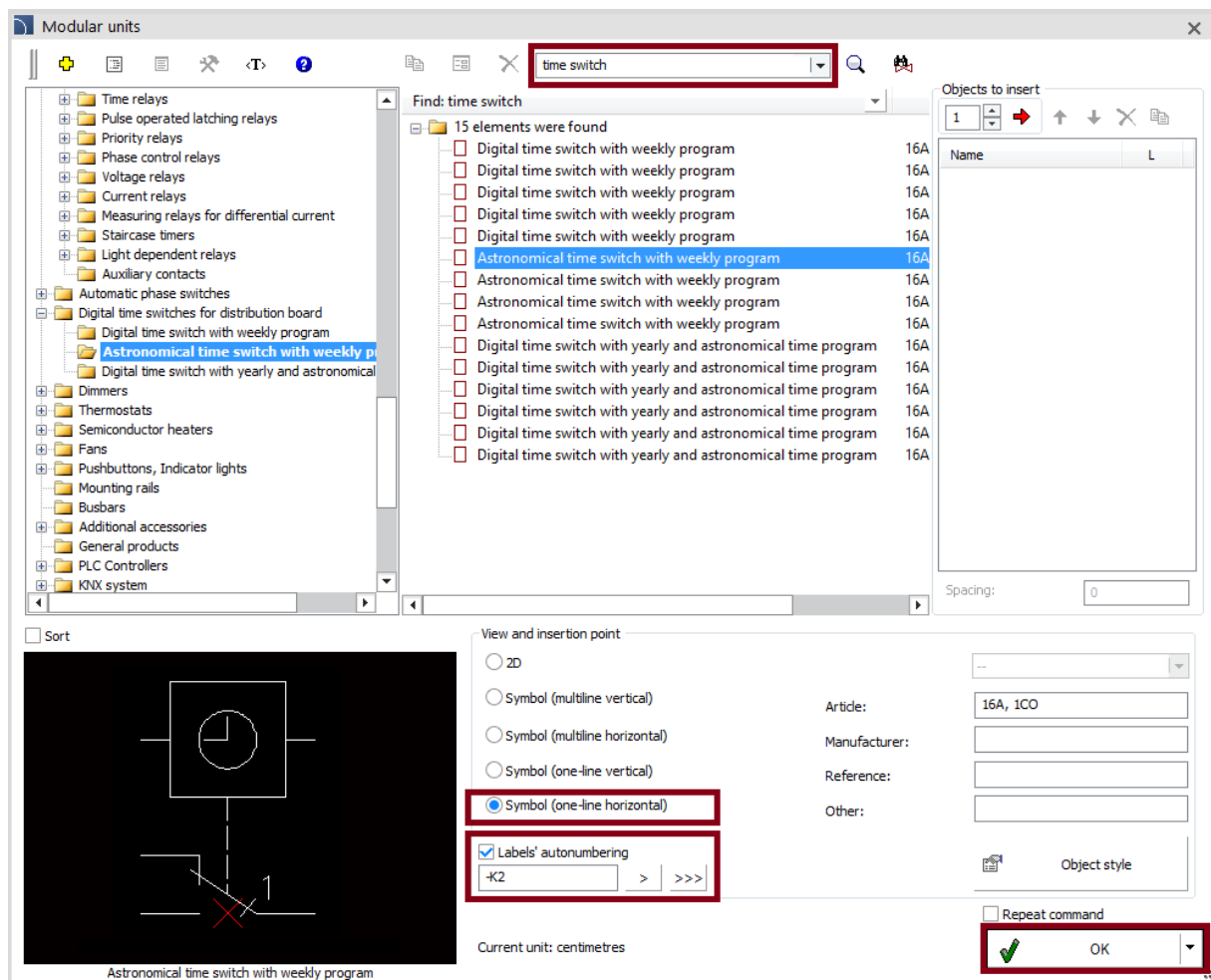

We choose the product that we are interested in (in our case it will be *astronomical time switch with weekly program*). We give the first free label (in our case it will be K2) and click the *OK* button.

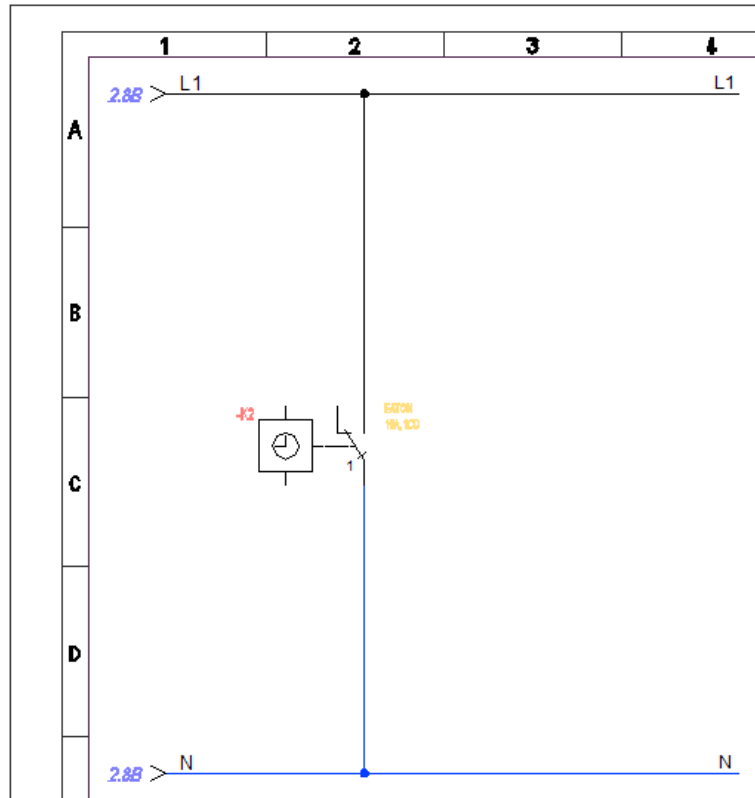

We insert our symbol directly into the project.



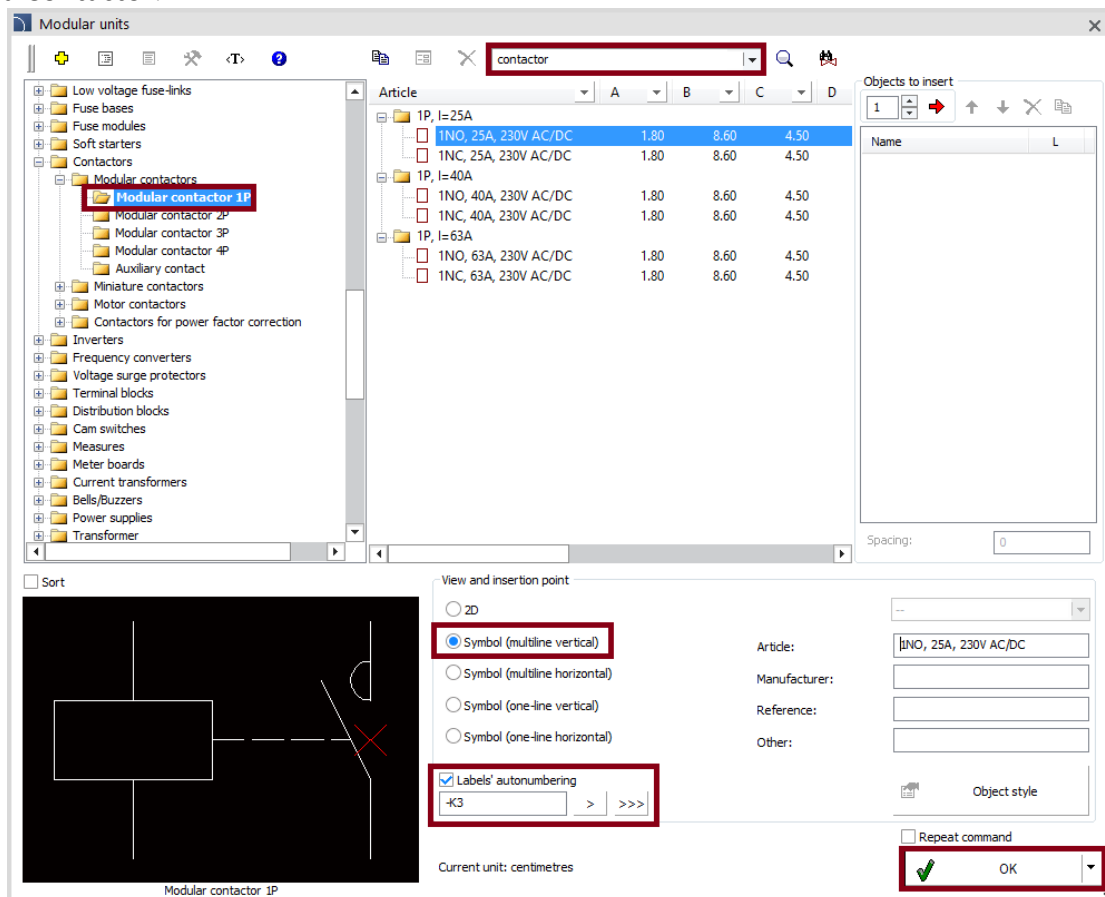

Again, we go to the *Modular units* command . By using the search option , we search for a Contactor.

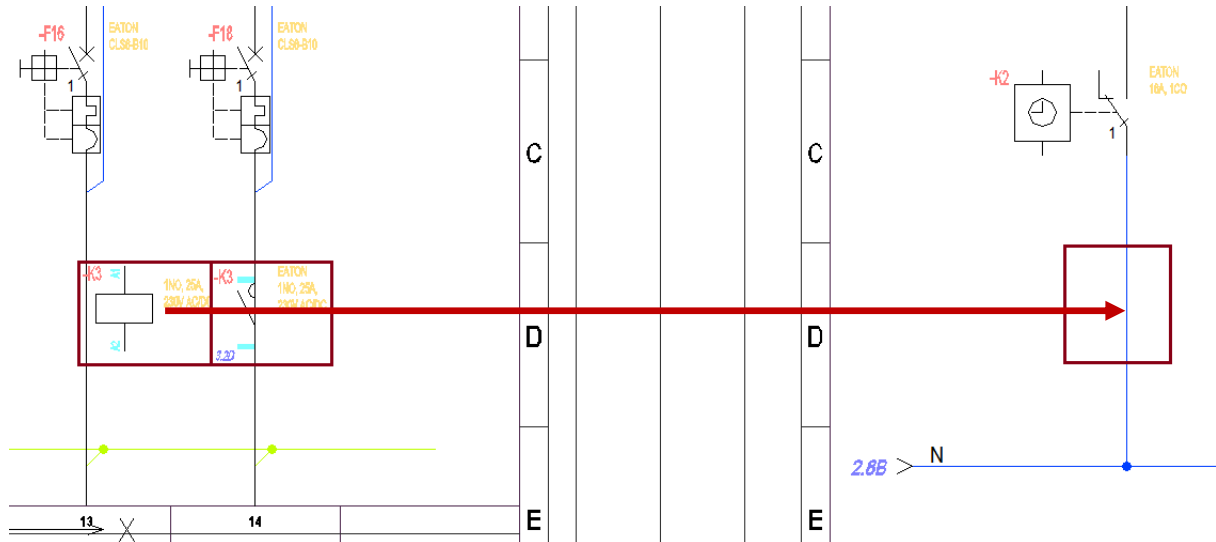

We select the *modular contactor 1P* and we choose the view as *Symbol (multiline vertical)*. We give the first free label (in our case it will be K3) and we click the *OK* button.

We insert the contactor's current contact into the external lighting circuit. Afterwards we will move the coil to the control circuit sheet.



Coil can be conveniently moved by using CADprofi editing commands. To do this, click the *Quick edit* button  on the *CADprofi - Edit* toolbar.



Then we select the coil, click the *Move* button...

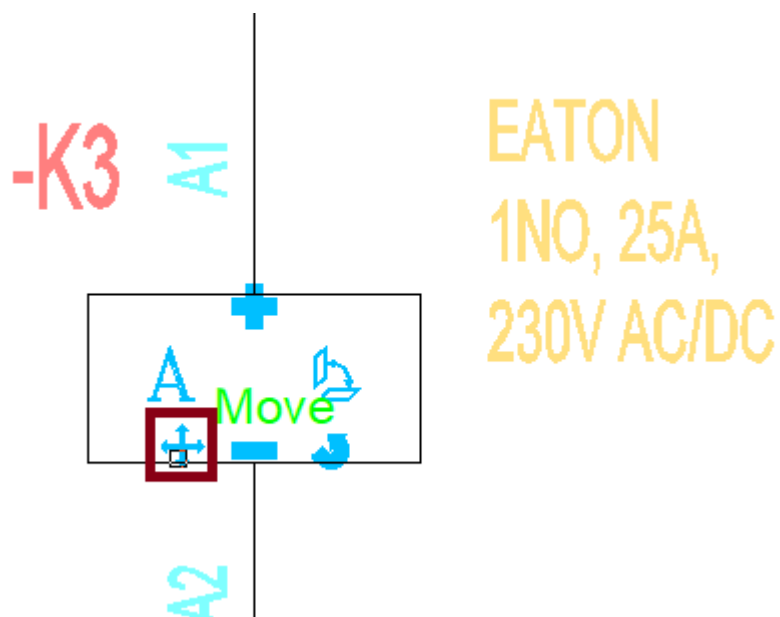

...and we move the symbol into the control circuit sheet.

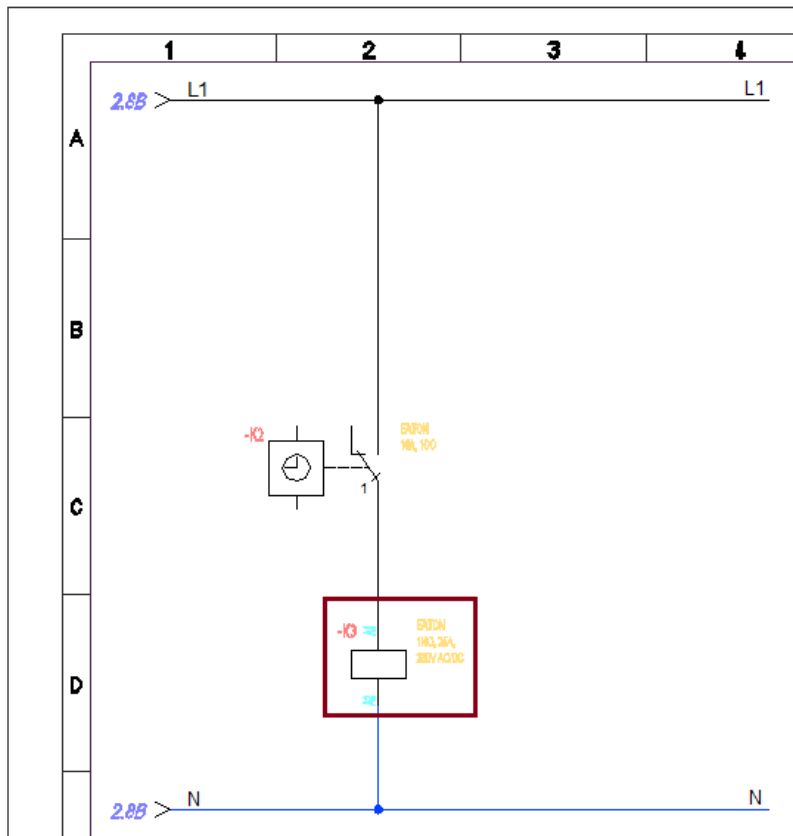

The next step is to address the components of the contactor. We go to the *Symbols - IEC, NFPA* library located on the *CADprofi - Electrical* toolbar.



In the following category - *Vertical symbols -> Switchgear, control and protective devices*, we select the *Contactors reference* symbol.

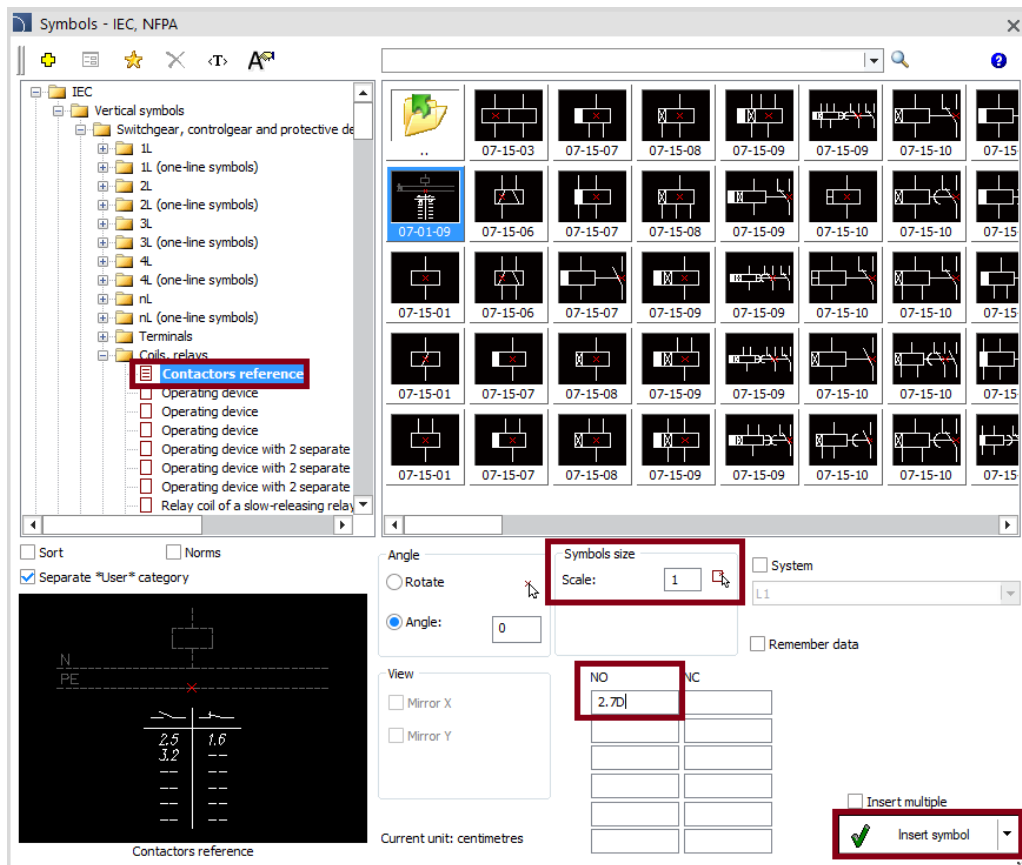

We set the size of the symbol to 1. We describe the NO contact address at 2.7D and we click the *Insert* button.

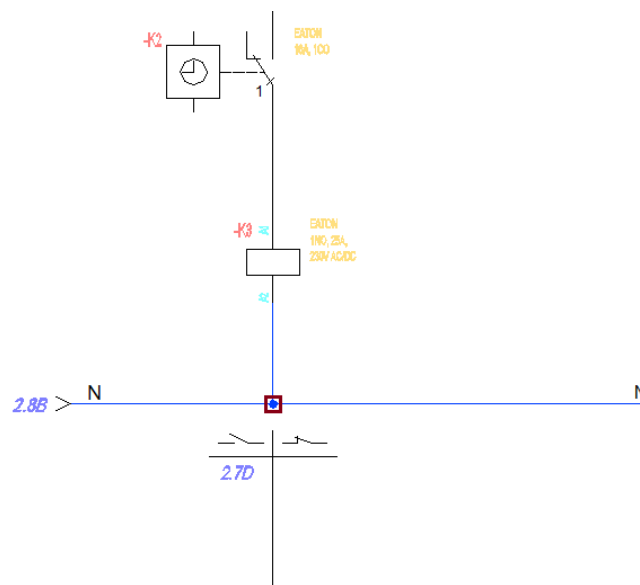

In the next step, we will insert a control circuit protection. We click on the *Insert similar object* command  located on the *CADprofi - Edit* toolbar.



Afterwards we click on the symbol of the overcurrent switch located on the external lighting circuit of the building.

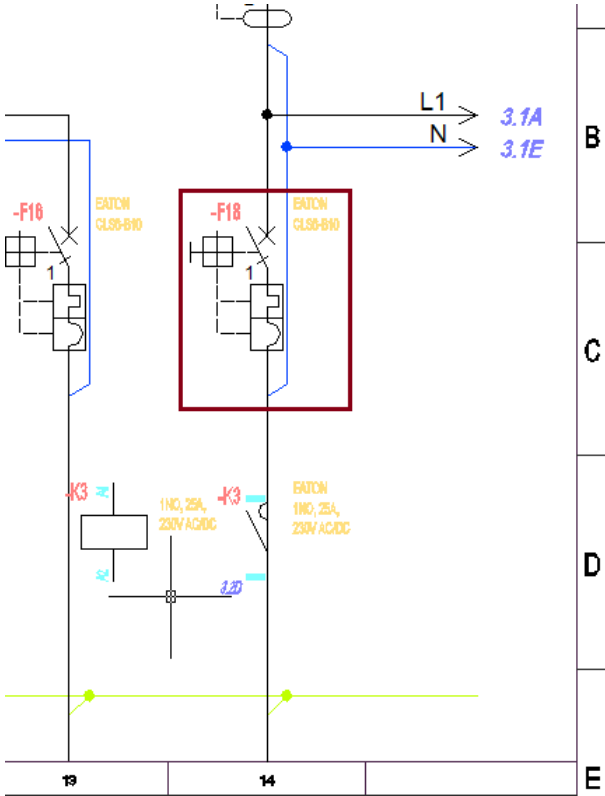

Thanks to the *Insert similar object* command, program will open the selected symbol in its original dialog window. Thanks to this, we will be able to conveniently choose a similar symbol - *modular circuit breaker B6*, which we then insert into the external circuit control scheme.

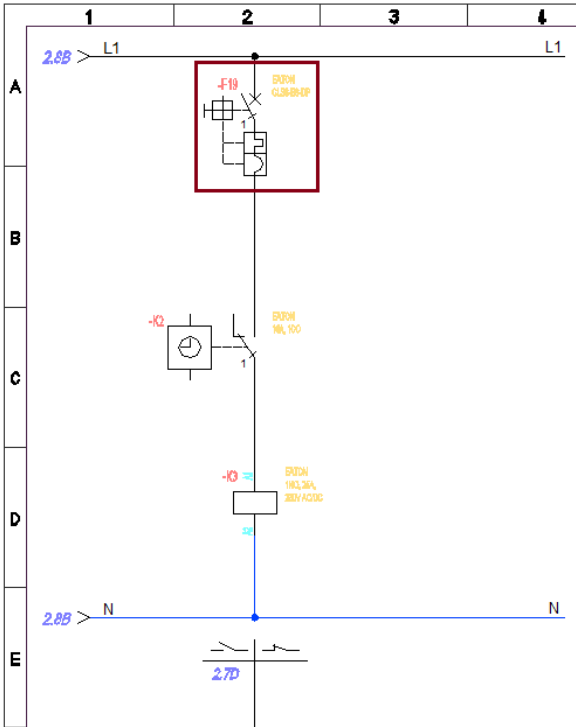

In the next step, we will draw the missing connections. To do this, click the *Lines, cable trays - schematics* button on the *CADprofi - Electrical* toolbar.

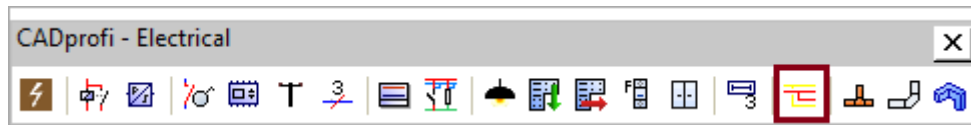

In the dialog window, we select the L1 cable (by double-clicking or selecting and pressing the arrow button). In the settings we will additionally select the option *Advanced Ortho - 2 segments*.

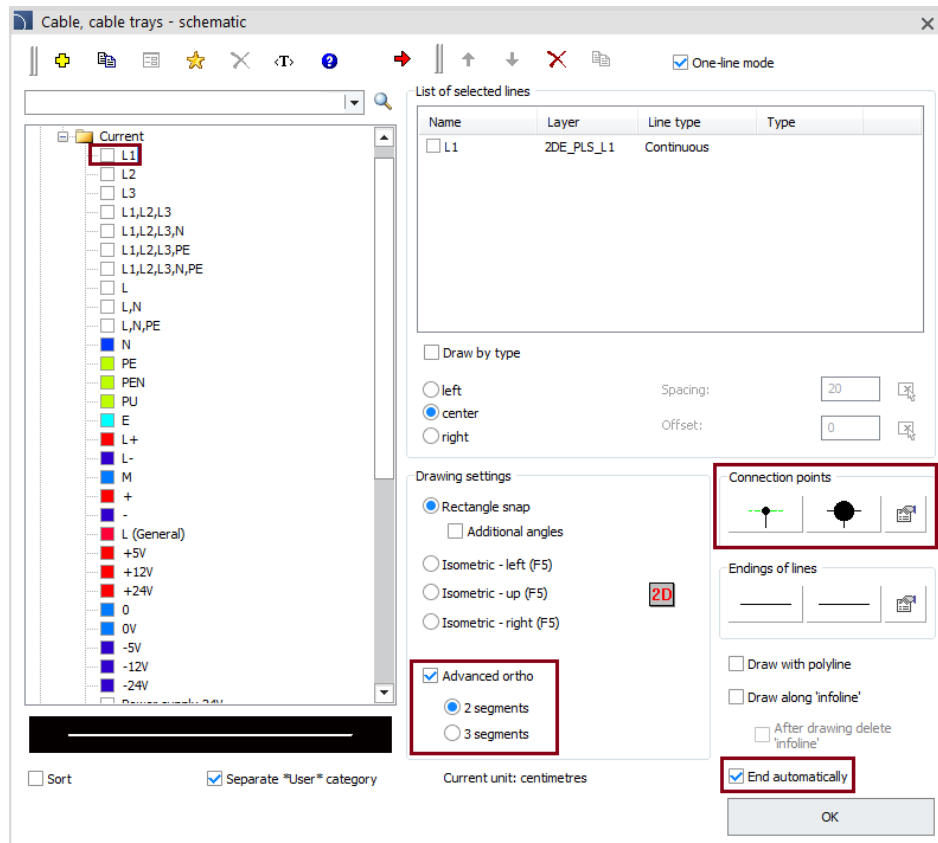

We will draw the line in two places (marked in red in the drawing below). Then, by using the command from the base CAD program *Match properties (matchprop)*, we will first select the neutral line, and then we will select lines whose properties we want to match with it (marked in green in the drawing below).

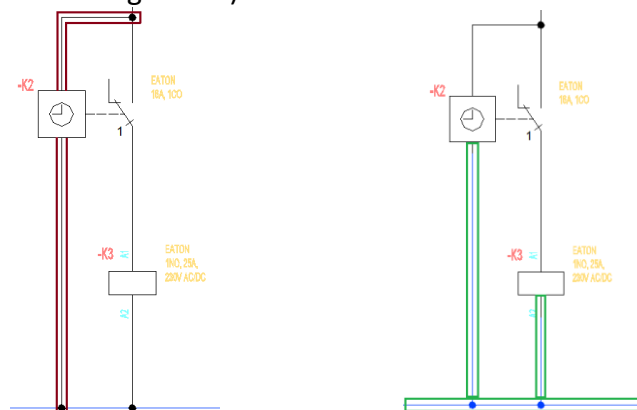

Generating legend

CADprofi program allows user to create various types of data specifications/bill of materials. One of the types of specification is a graphic legend that contains symbols used in the project.

To insert a legend, we run the *Bill of materials* command located on the *CADprofi* toolbar.



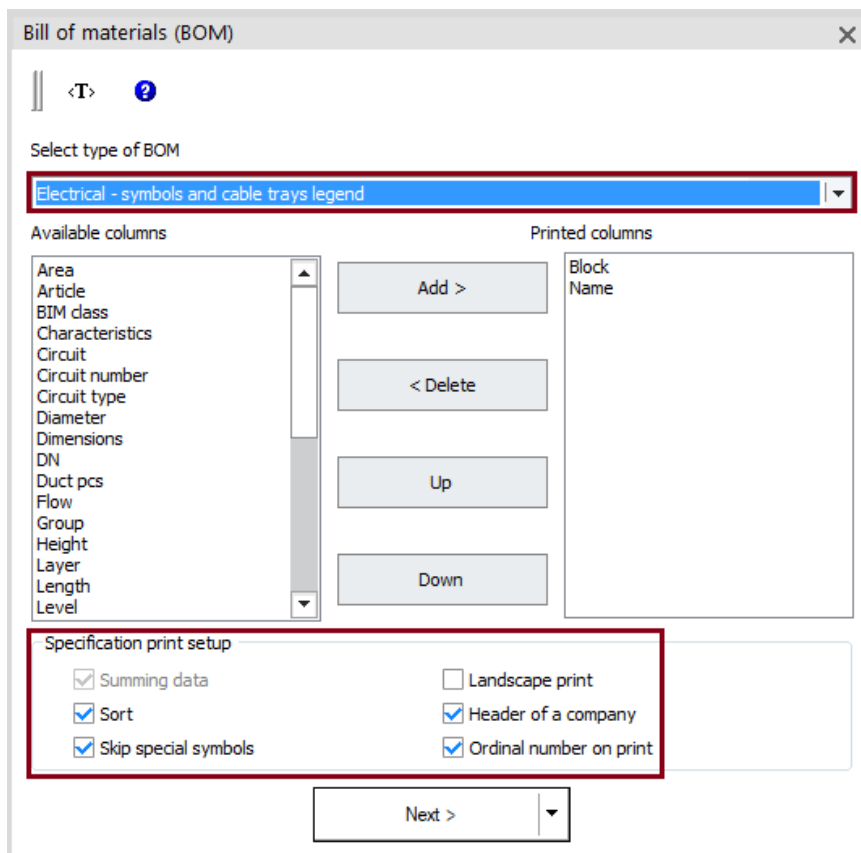

We select the BOM type as: *Electrical – symbols and cable trays legend*.

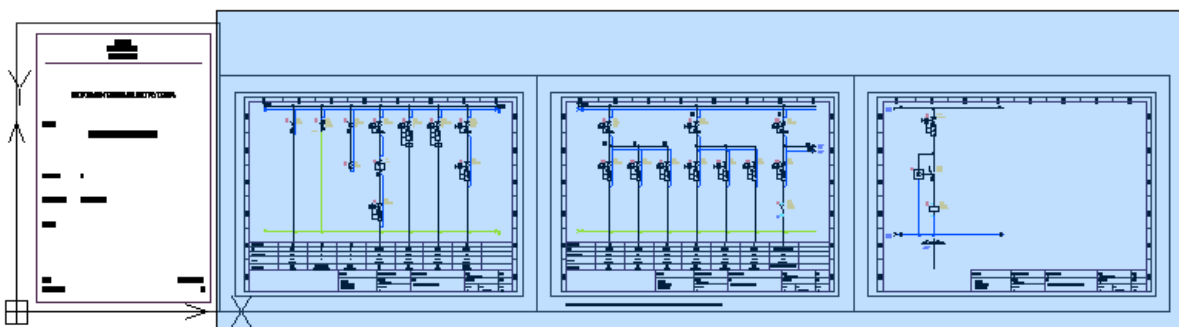

After pressing the Next button, we will select all objects from the project and press the  button.



In the next dialog box, a list of all objects and symbols will be displayed. We can remove unnecessary objects and change their order. For example, we will delete lines 1, L1, N, PE (select them and press the  key or click the *Remove*  button).

The width of individual data in the legend inserted into the drawing is proportional to the width of the columns of the list. We can change the widths by dragging the header fields.

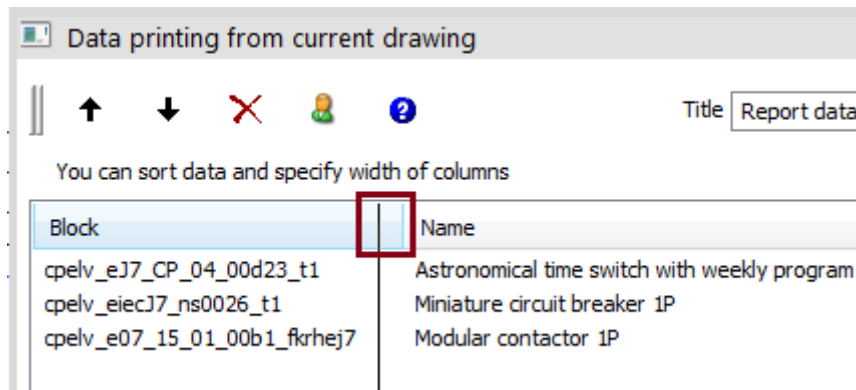

To insert a legend into a drawing, we click the *Draw* button. In the next dialog box we will define legend parameters.

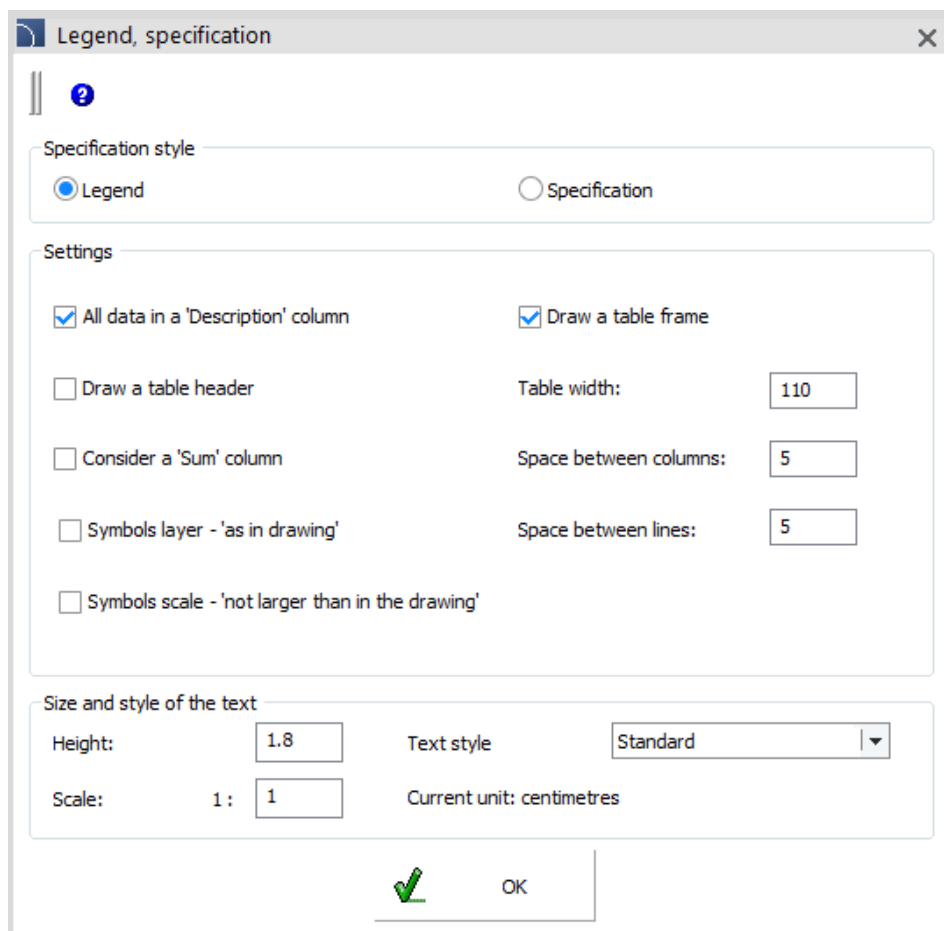

To insert the legend shown here, we need to choose the following options:

- Specification style – *Legend*
- All data in a 'Description' column
- Draw a table frame
- Table width – 110
- Text height – 1.8
- Text scale – 1:1

After specifying the parameters, we click the *OK* button and we insert the legend into the drawing. The legend is drawn down from the indicated point, if necessary, we can move it to the appropriate place by using the *Move* command (`_move`) from the base CAD program.

	Automatyczny przełącznik faz
	Lampka kontrolna 3-fazowa
	Ochronnik przeciwprzepięciowy 4P (Typ 1+2)
	Rozłącznik bezpiecznikowy 3P
	Rozłącznik główny 3P

The descriptive texts located next to the symbols in the legend can be easily removed with the *CADprofi - Explode* command located on the *CADprofi - Edit* toolbar.



We select the *Put exploded elements on source object layer* option and we click the *OK* button.

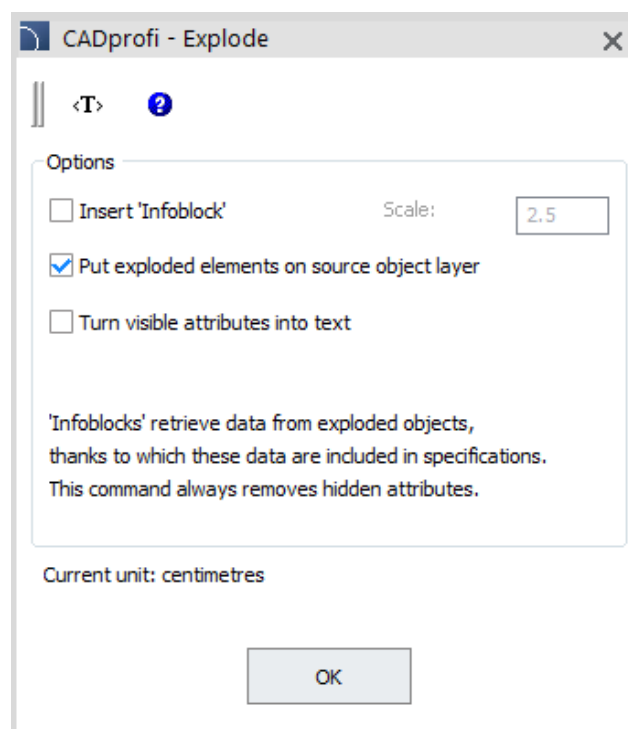

Afterwards we select our legend - the descriptive texts will then be deleted.

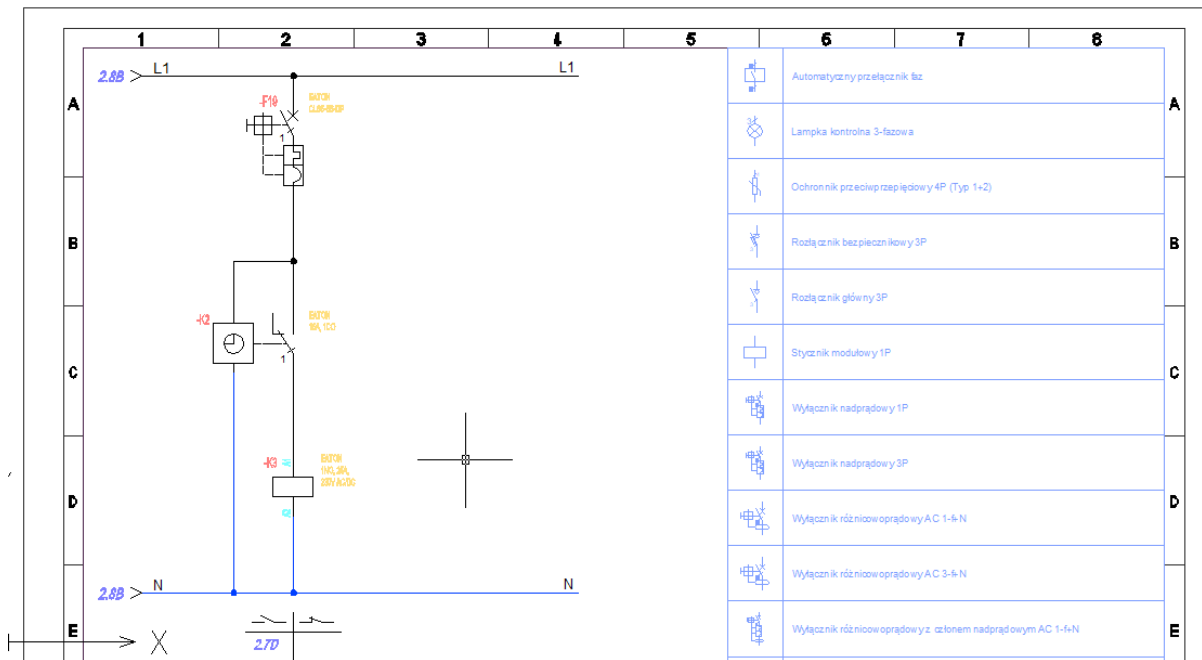

Generating apparatus views

Next step will be to generate apparatus views based on the symbols used in the project.

We click the *Bill of materials* button . From the list of available specifications, we find *Electrical – Insert 2D views from selected symbols* and afterwards we click the *Next* button.

Select type of BOM

Electrical - Insert 2D views from selected symbols

Afterwards we select symbols on the basis of which we want to generate the apparatus views.

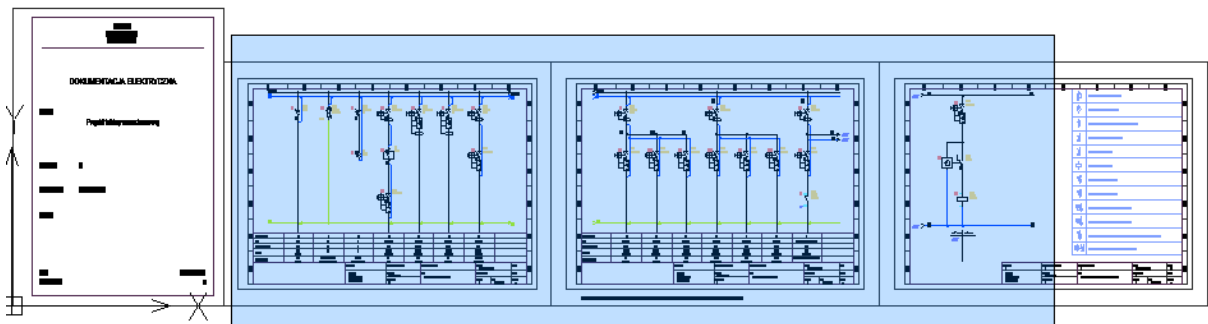

In the newly opened window program will generate a list of views. We click the *Insert 2D views* button.

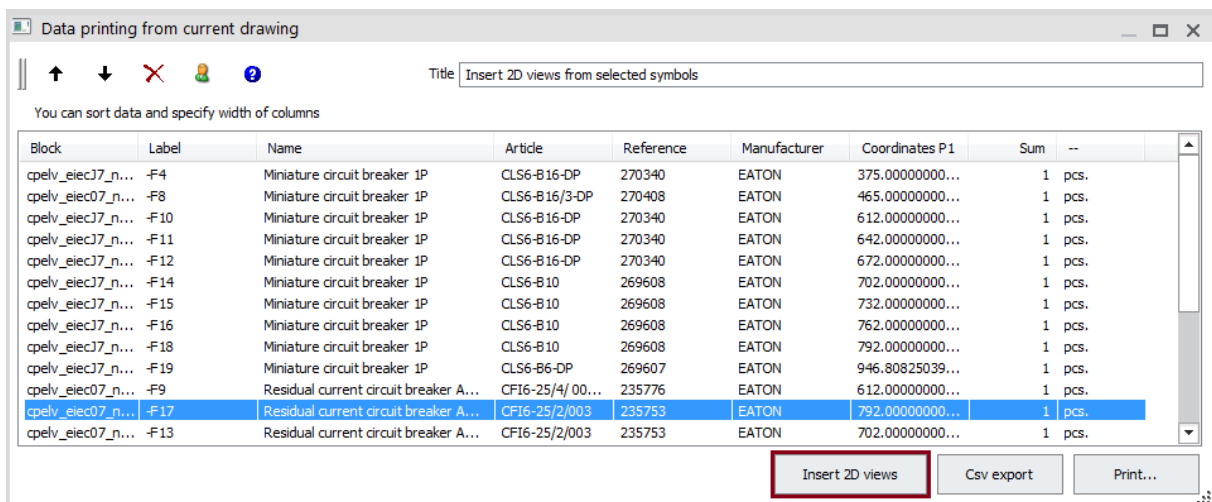

Data printing from current drawing

Title: Insert 2D views from selected symbols

You can sort data and specify width of columns

Block	Label	Name	Article	Reference	Manufacturer	Coordinates P1	Sum	--
cpelv_eiecJ7_n...	-F4	Miniature circuit breaker 1P	CLS6-B16-DP	270340	EATON	375.00000000...	1 pcs.	
cpelv_eiec07_n...	-F8	Miniature circuit breaker 1P	CLS6-B16/3-DP	270408	EATON	465.00000000...	1 pcs.	
cpelv_eiecJ7_n...	-F10	Miniature circuit breaker 1P	CLS6-B16-DP	270340	EATON	612.00000000...	1 pcs.	
cpelv_eiecJ7_n...	-F11	Miniature circuit breaker 1P	CLS6-B16-DP	270340	EATON	642.00000000...	1 pcs.	
cpelv_eiecJ7_n...	-F12	Miniature circuit breaker 1P	CLS6-B16-DP	270340	EATON	672.00000000...	1 pcs.	
cpelv_eiecJ7_n...	-F14	Miniature circuit breaker 1P	CLS6-B10	269608	EATON	702.00000000...	1 pcs.	
cpelv_eiecJ7_n...	-F15	Miniature circuit breaker 1P	CLS6-B10	269608	EATON	732.00000000...	1 pcs.	
cpelv_eiecJ7_n...	-F16	Miniature circuit breaker 1P	CLS6-B10	269608	EATON	762.00000000...	1 pcs.	
cpelv_eiecJ7_n...	-F18	Miniature circuit breaker 1P	CLS6-B10	269608	EATON	792.00000000...	1 pcs.	
cpelv_eiecJ7_n...	-F19	Miniature circuit breaker 1P	CLS6-B6-DP	269607	EATON	946.80825039...	1 pcs.	
cpelv_eiec07_n...	-F9	Residual current circuit breaker A...	CFI6-25/4/00...	235776	EATON	612.00000000...	1 pcs.	
cpelv_eiec07_n...	-F17	Residual current circuit breaker A...	CFI6-25/2/003	235753	EATON	792.00000000...	1 pcs.	
cpelv_eiec07_n...	-F13	Residual current circuit breaker A...	CFI6-25/2/003	235753	EATON	702.00000000...	1 pcs.	

Buttons: Insert 2D views, Csv export, Print...

Afterwards we click anywhere in the drawing and program will automatically generate apparatus views.

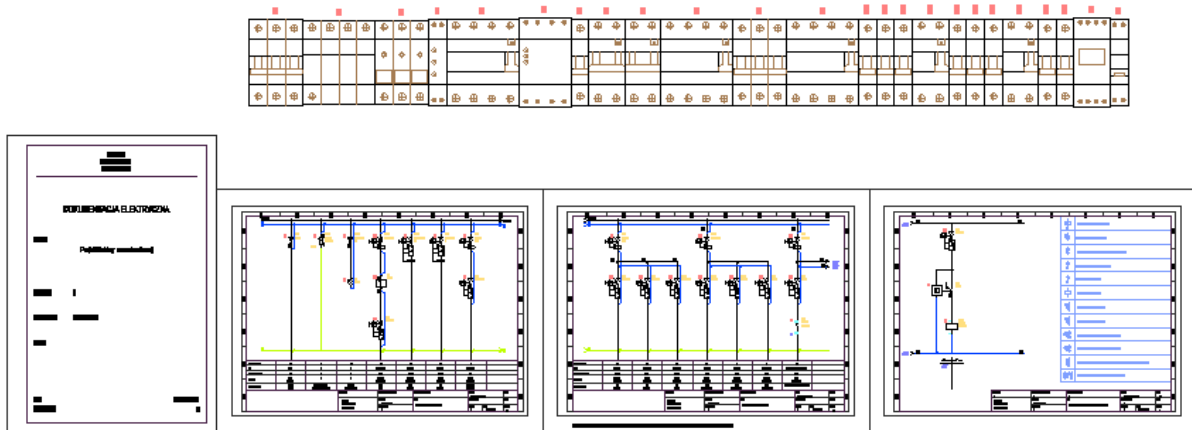

Selection electrical switchgear

In the next step, we will select an electrical switchgear. To do this, we run the *Switchgear* command located on the *CADprofi - Electrical* toolbar.

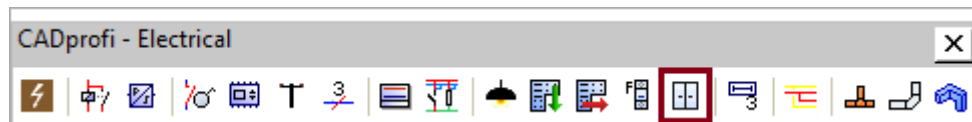

Command allows us to automatically select the switchgear on the basis of devices selected from the drawing. Additionally, this command allows us to specify a reserve when selecting a cabinet. We will use this option and set the reserve when selecting the cabinet at 30% and then click the *Cabinet* button.

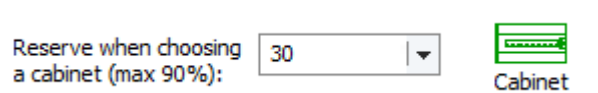

We select the generated apparatus views, and then we click the *Enter* button.

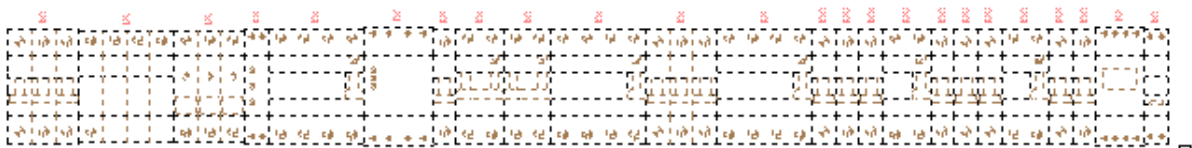

Program offers us several available cabinets, taking into account the necessary space for modular equipment and a 30% reserve.

Select modular switchgear:
moduls count 65 (reserve=30%)

We select a 3-row switchgear with 72 modules (3.x24) and we click the *OK* button.

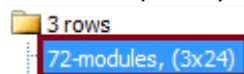

In the new window, we describe the switchgear (type, manufacturer) and we give the first free label -U1.

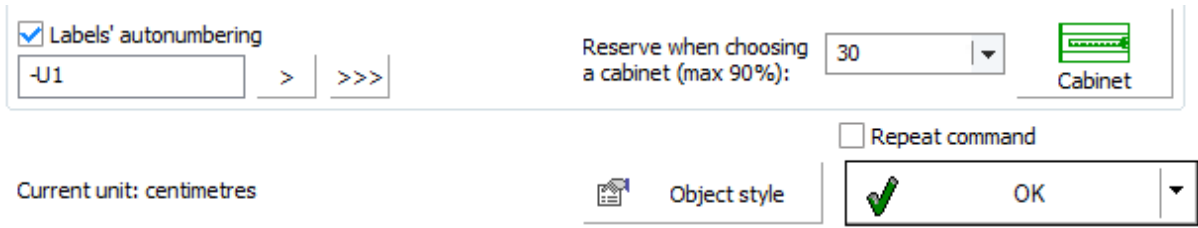

We click the *OK* button and we place the switchgear in the project.

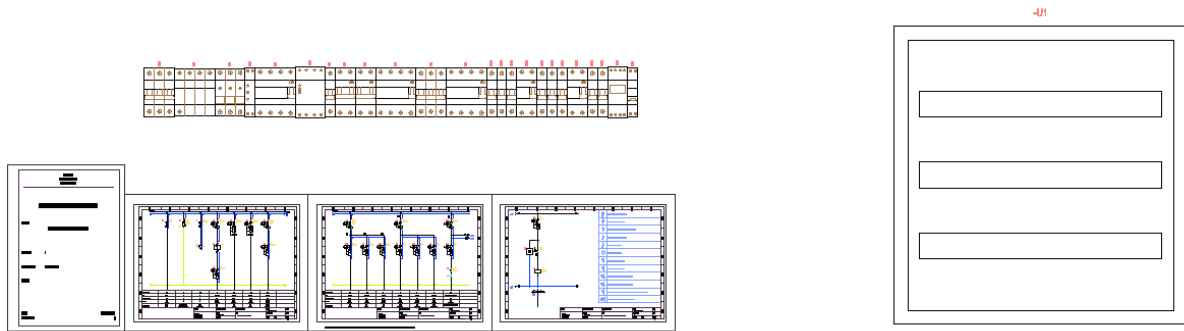

In the next step, by using the basic CAD program command - move, we will *move* the apparatus to the appropriate places in our switchgear. Thanks to this, we will achieve the following effect:

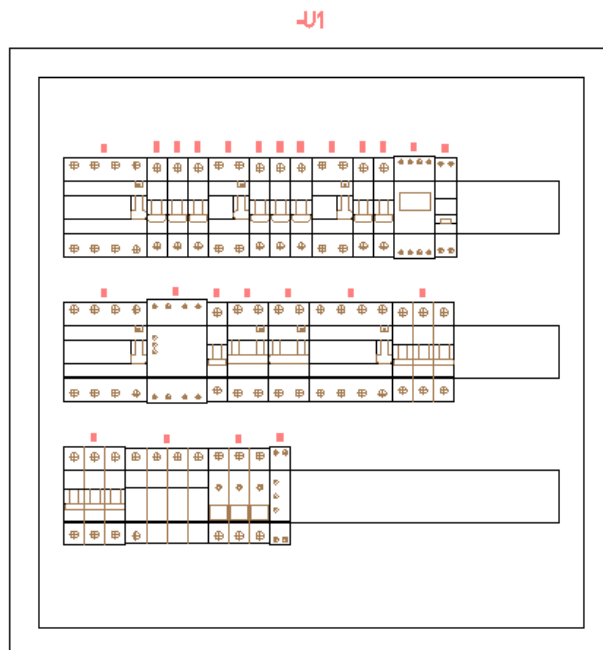

Printing the project

Creating and printing BOM (bill of materials)

To create a data extract with a list of devices used in the project, we have to run the *Bill of materials* command  that is located on the *CADprofi* toolbar.

In the dialog window, we select the type of specification: *Electrical - symbols and objects*.

Select type of BOM

Electrical - symbols and objects

We remove the System and Voltage columns by using the *Remove* button. We enable the following options:

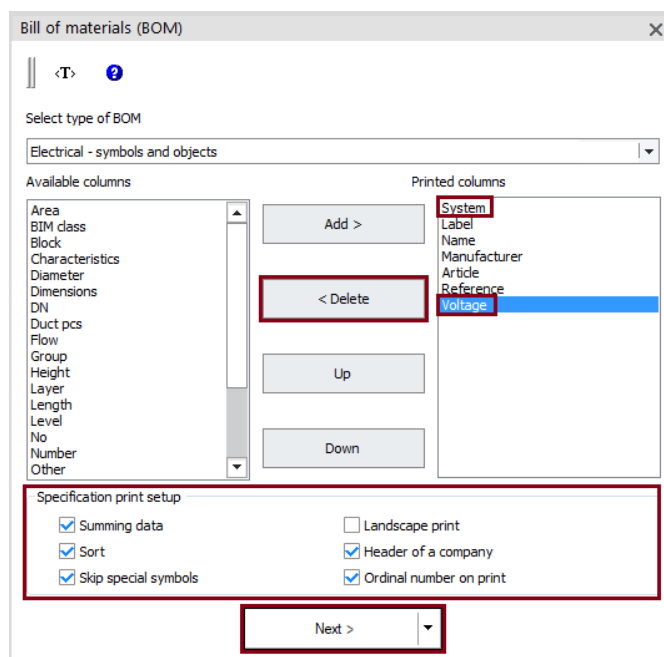

Then we click the *Next>* button and select all objects from the drawing.

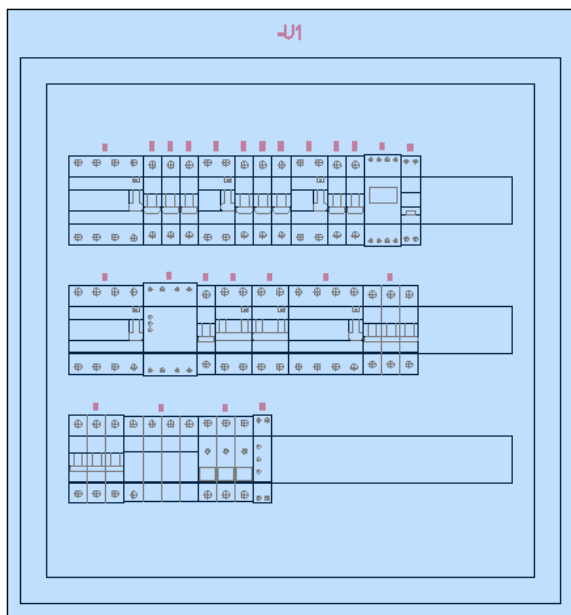

After the selection of objects is finished we will click the  key and a window with a complete material list appears. By dragging the cursor displayed between the column titles, you can change the width of the columns and hide selected columns. By clicking on the column title, we can also sort the data.

We can organize the list by using the *Up*, *Down* and *Remove* buttons. By using the *Down* button  move the cylindrical fuse to the very bottom of our list.

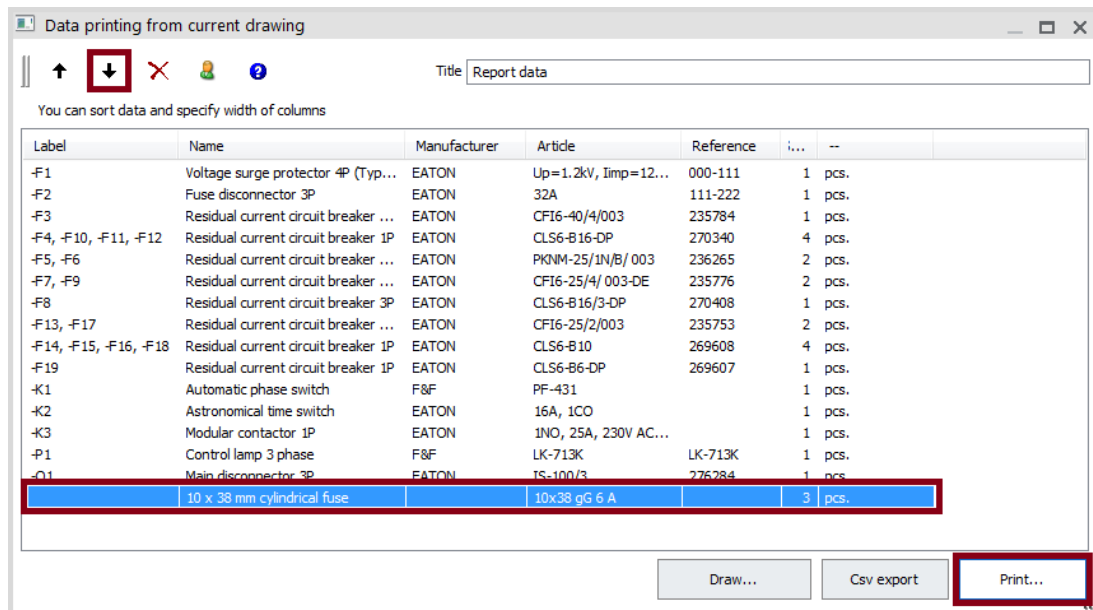

We can export BOM to a csv file or print it. We will use the print option.

We click the *Print* button. In the next dialog box, we can print the data or export it to many formats (xls, pdf, etc.). In our case we want to print the data. It's a good idea to see the layout before printing, so we choose *Preview*. After clicking the *Start* button, a preview of the specification list will be displayed.

To print specification, click the printer icon in the preview window.

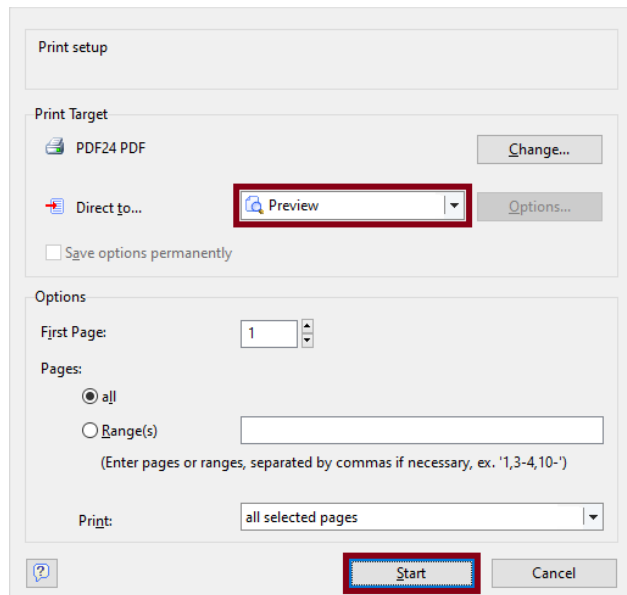

The preview of our printout will look like this:

Report data

Nr.	Label	Name	Manufacturer	Article	Reference	Sum	--
1	-F1	Voltage surge protector 4P (Type 1+2)	EATON	Up=1.2kV, Iimp=12.5kA	000-111	1	pcs.
2	-F2	Fuse disconnecter 3P	EATON	32A	111-222	1	pcs.
3	-F3	Residual current circuit breaker AC 3-f+N	EATON	CFI6-40/4/003	235784	1	pcs.
4	-F4, -F10, -F11, -F12	Residual current circuit breaker 1P	EATON	CLS6-B16-DP	270340	4	pcs.
5	-F5, -F6	Residual current circuit breaker AC 1-f+N	EATON	PKNM-25/1N/B/003	236265	2	pcs.
6	-F7, -F9	Residual current circuit breaker AC 3-f+N	EATON	CFI6-25/4/003-DE	235776	2	pcs.
7	-F8	Residual current circuit breaker 3P	EATON	CLS6-B16/3-DP	270408	1	pcs.
8	-F13, -F17	Residual current circuit breaker AC 1-f+N	EATON	CFI6-25/2/003	235753	2	pcs.
9	-F14, -F15, -F16, -F18	Residual current circuit breaker 1P	EATON	CLS6-B10	269608	4	pcs.
10	-F19	Residual current circuit breaker 1P	EATON	CLS6-B6-DP	269607	1	pcs.
11	-K1	Automatic phase switch	F&F	PF-431		1	pcs.
12	-K2	Astronomical time switch	EATON	16A, 1CO		1	pcs.

Printing the project

Now let's move on to the preparation of our project for printing. At the very beginning, we will go to the base CAD program layer manager. In the layer manager, we will turn off the layers that we want to omit from the printout. In our case, it will be the CP_HIDDE_APPARATUS layer.

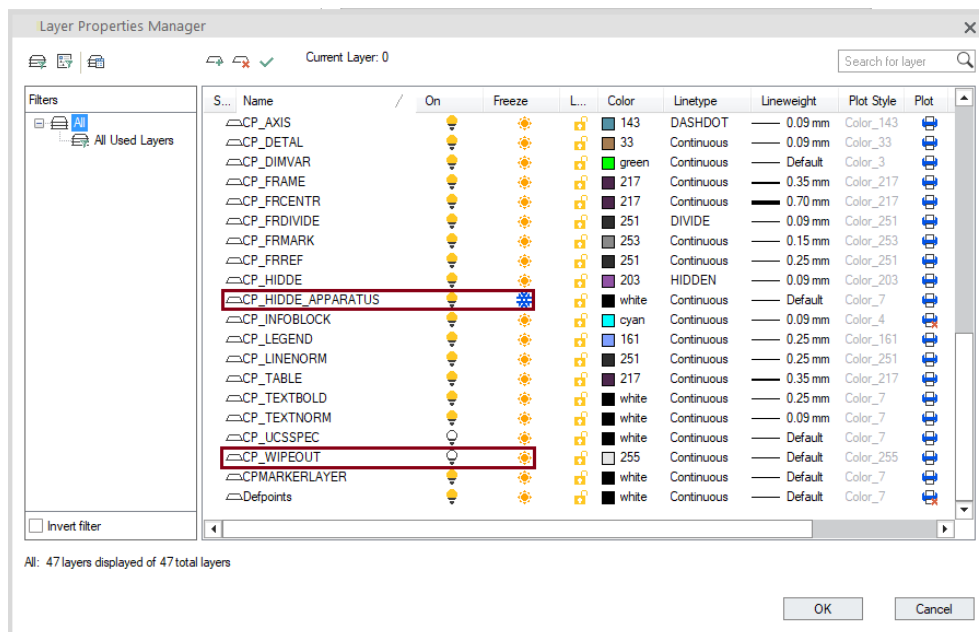

In the next step, let's move on to creating printout layouts. By right-clicking on the layout tab we select *Page setup*.

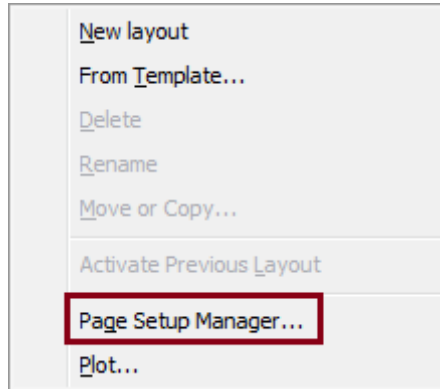

We select the following options in the page settings:

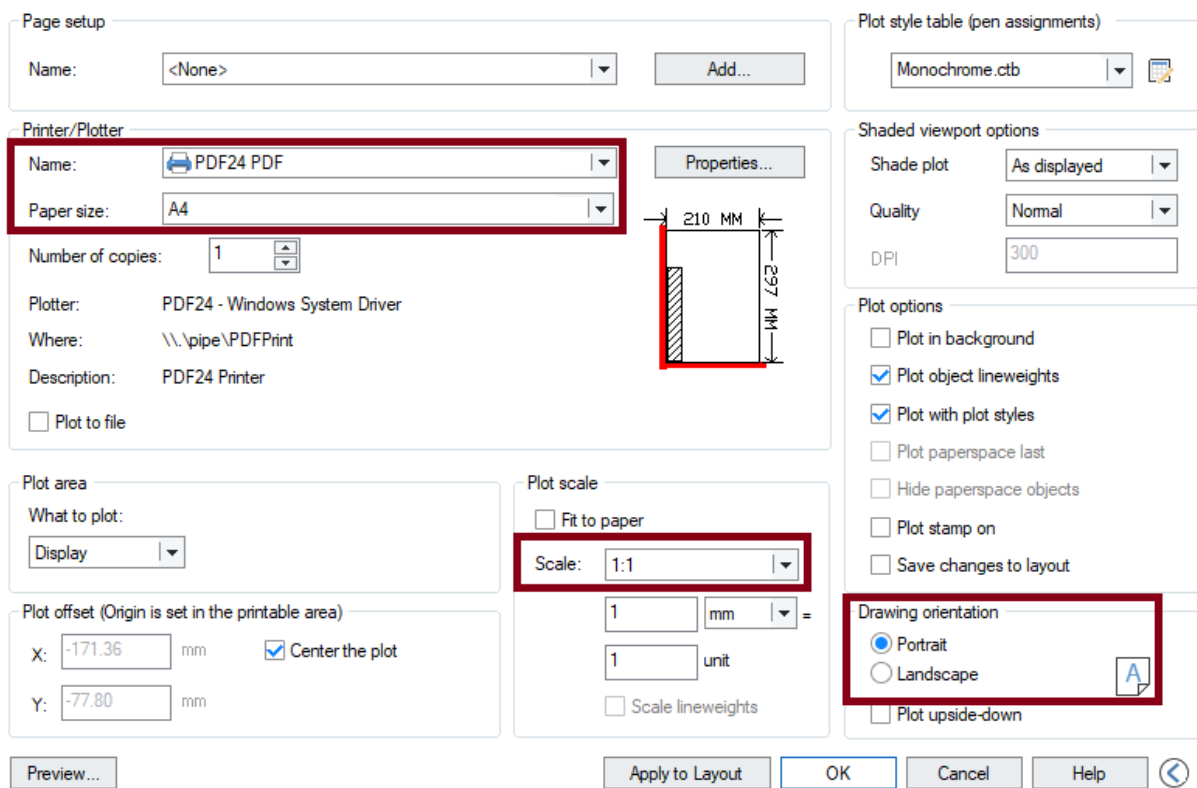

We print our project to a PDF file, set the paper size as A4, unit per millimeters, scale 1: 1. We will choose *Monochrome.ctb* as the print style. Since the first sheet of our printout will contain a cover page, we will select the print orientation as *Portrait*.

We click the OK button and then define the dimensions of our viewport. Height 297, width 210. Position X - 105, position Y-148.5.

View	
Center X	105.0000
Center Y	148.5000
Center Z	0.0000
Height	297.0000
Width	209.7247

We set the first sheet in the viewport, which is our title page.

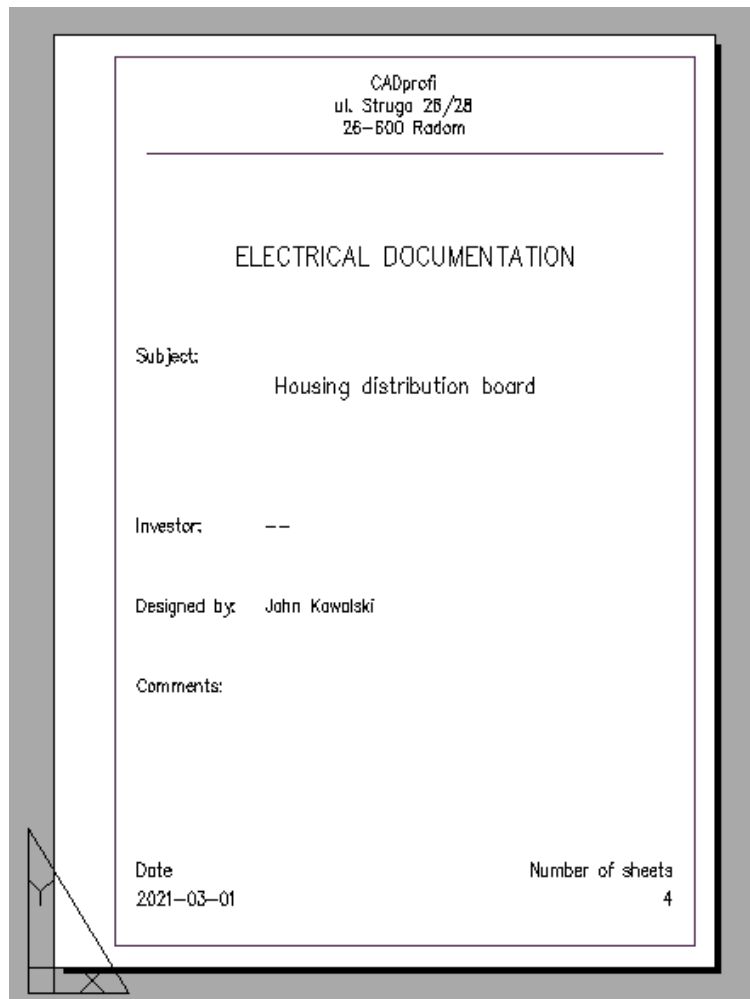

By right-clicking on the sheet name we select the *Print/Plot* option.

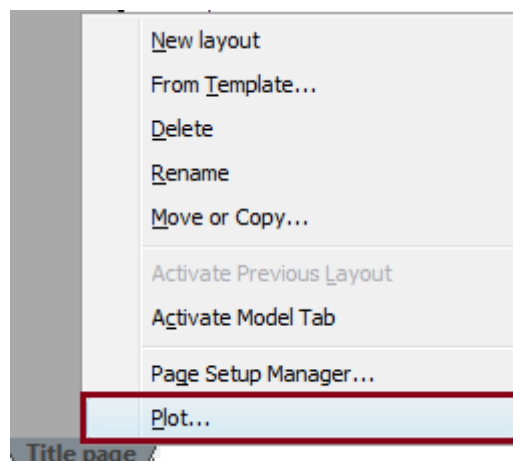

We click the *Preview* button to check the print preview.

In the following sheets, we will change the orientation from portrait to landscape. Therefore, the dimensions of the viewports on the remaining sheets will be opposite to those on the first sheet - height 210, width 297. Position X - 148.5, position Y-105.

So next sheets will look like this:

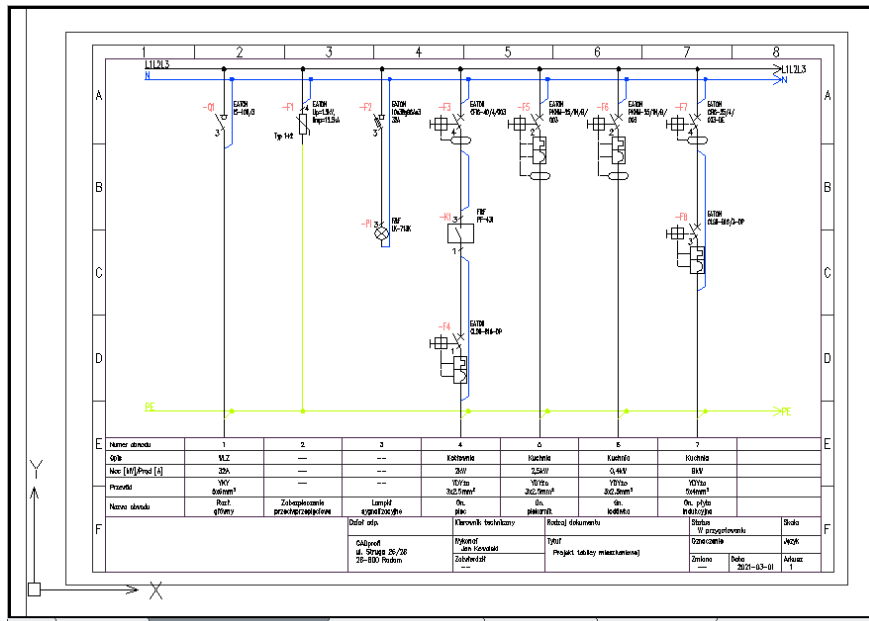

Model \ Stona tytulowa \ Schemat rozdziału energii -1 \ Schemat rozdziału energii -2 \ Obwód sterowania \ Widok rozdzielnic /

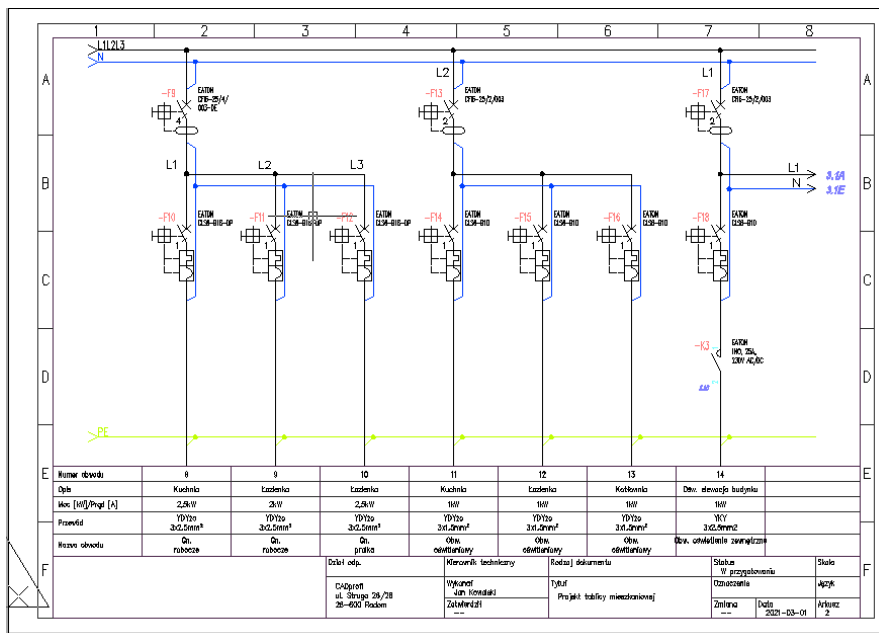

Model \ Stona tytulowa \ Schemat rozdziału energii -1 \ Schemat rozdziału energii -2 \ Obwód sterowania \ Widok rozdzielnic /

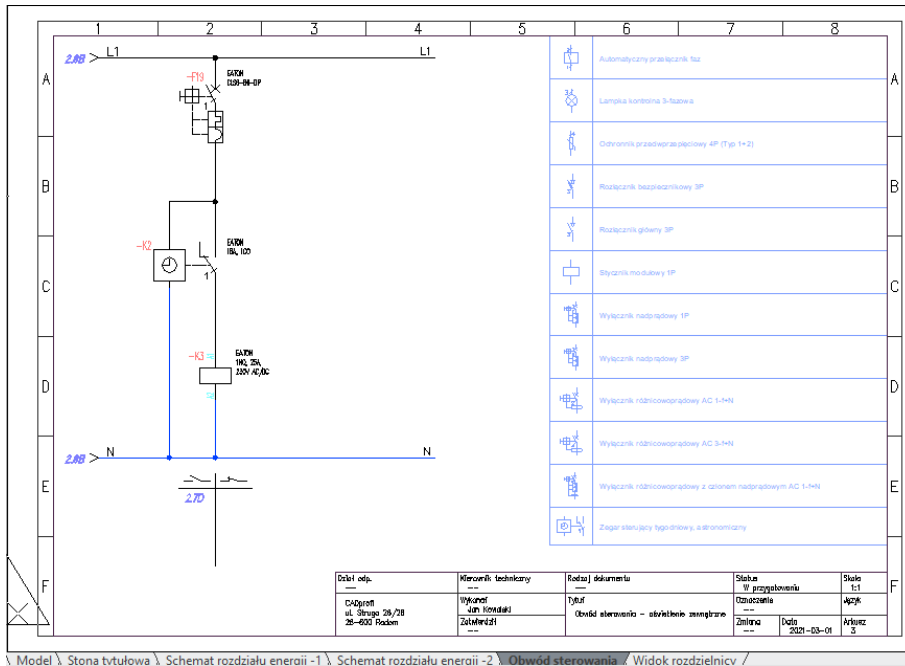

Model \ Stona tytulowa \ Schemat rozdziálu energii -1 \ Schemat rozdziálu energii -2 \ Obwód sterowania \ Widok rozdzielnic /

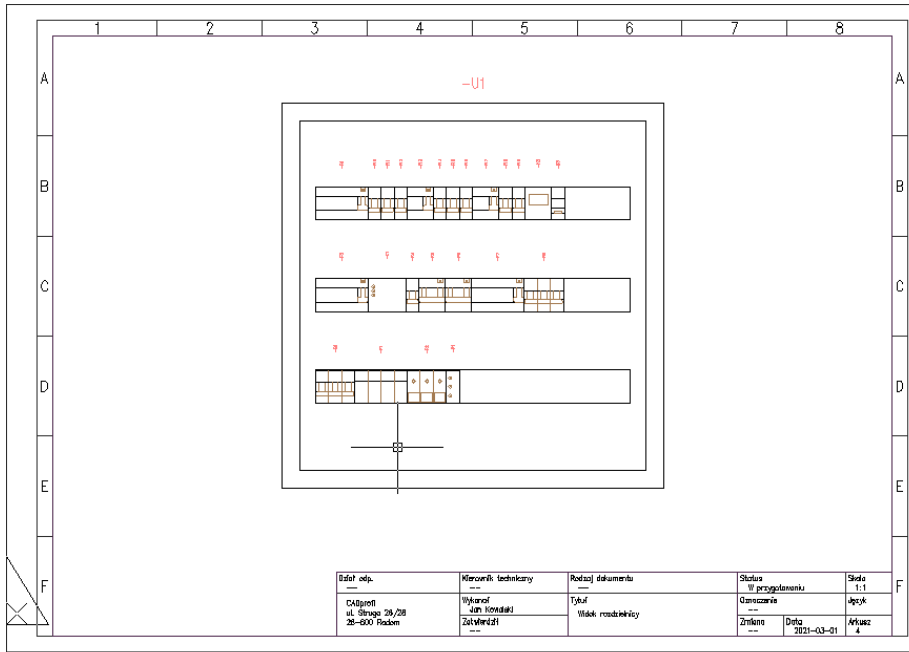

Model \ Stona tytulowa \ Schemat rozdziálu energii -1 \ Schemat rozdziálu energii -2 \ Obwód sterowania \ Widok rozdzielnic /

CADprofi – All changes are restricted